



US012460273B1

(12) **United States Patent**
Hoffman

(10) **Patent No.:** US 12,460,273 B1
(45) **Date of Patent:** Nov. 4, 2025

- (54) **LEATHER BURNISHING TOOL**
- (71) Applicant: **Christopher Hoffman**, Bayonne, NJ (US)
- (72) Inventor: **Christopher Hoffman**, Bayonne, NJ (US)
- (*) Notice: Subject to any disclaimer, the term of this patent is extended or adjusted under 35 U.S.C. 154(b) by 0 days.
- (21) Appl. No.: **18/777,577**
- (22) **Filed:** Jul. 19, 2024
- (51) **Int. Cl.**
C14B 19/00 (2006.01)
C14B 11/00 (2006.01)
- (52) **U.S. Cl.**
CPC *C14B 19/00* (2013.01); *C14B 11/00* (2013.01); *C14B 2700/14* (2013.01)
- (58) **Field of Classification Search**
CPC C14B 11/00; C14B 19/00; C14B 2700/14; A43D 95/22; A43D 95/16
USPC 69/20
See application file for complete search history.

- 446,923 A * 2/1891 Miller C14B 9/00 69/17
- 544,399 A * 8/1895 Arnold C14B 1/00 69/8
- 761,696 A * 6/1904 McCarter et al. C14B 11/00 69/7.7
- 1,042,607 A * 10/1912 Schneider A43D 87/00 12/92
- 1,253,650 A * 1/1918 Van Guelpen C14B 11/00 69/7.7
- 1,280,710 A * 10/1918 Glass C14B 11/00 69/7.7
- 1,317,452 A * 9/1919 Packard C14B 11/00 69/7.7
- 1,339,776 A * 5/1920 Merrick C14B 11/00 12/146 CK
- 1,362,762 A * 12/1920 Van Guelpen C14B 11/00 69/7.7

(Continued)

OTHER PUBLICATIONS

Just Wood: Leather Burisher Bundle, https://web.archive.org/web/20240416150523/https://www.justwood.com/buy/leather-burnisher-bundle-with-motor-drum-sander_167.htm, Apr. 16, 2024 (Year: 2024).*

Primary Examiner — Heather Mangine
(74) Attorney, Agent, or Firm — Gearhart Law LLC

(56) **References Cited**

U.S. PATENT DOCUMENTS

- 95,779 A * 10/1869 Cunningham C14B 1/00 69/21
- 215,705 A * 5/1879 Wood C14B 11/00 69/17
- 286,128 A * 10/1883 Gordon A43D 95/20 12/77
- 316,867 A * 4/1885 Beaudry A43D 25/066 12/127
- 356,839 A * 2/1887 Hutchinson C14B 11/00 12/51
- 377,574 A * 2/1888 Patch A43D 95/20 12/77

(57) **ABSTRACT**

A leather burnishing tool is described. The tool has a central body portion that may be held by a user and a working portion on at least one end. In a preferred embodiment, the central body portion has two working portions. Each working portion is configured to snap into or otherwise securely engage the central body. Each working portion preferably has at least one and more preferably two shaping channels configured to burnish or shape leather. The tool is preferably continuously slid along the edge (or the leather slid along the shaping channel(s)) of the piece of leather to shape the edge of the piece of leather.

10 Claims, 13 Drawing Sheets

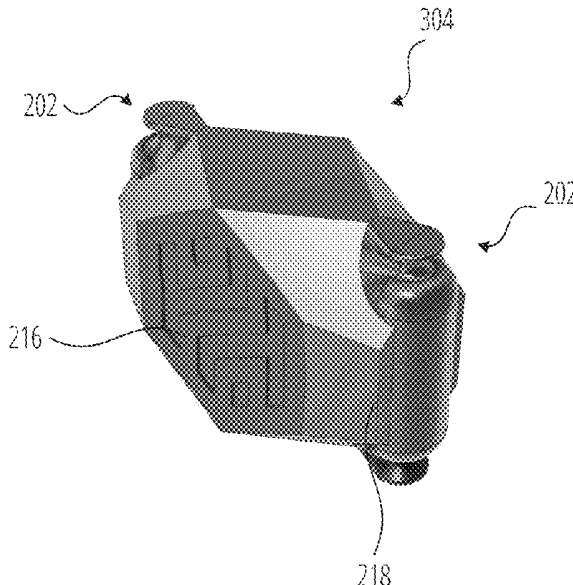

(56)

References Cited

U.S. PATENT DOCUMENTS

1,365,389 A *	1/1921	Feige	C14B 11/00 69/7.7	2,301,210 A *	11/1942	Hamann	A43D 95/22 12/78
1,417,202 A *	5/1922	Puls	A43D 95/20 12/77	2,416,289 A *	2/1947	Cross	C14B 1/44 493/271
1,423,051 A *	7/1922	Van Guelpen	C14B 11/00 69/7.7	2,571,149 A *	10/1951	Maciejowski	C14B 1/38 69/48
1,423,052 A *	7/1922	Van Guelpen	A43D 95/22 69/7.7	2,571,792 A *	10/1951	Tosi	C14B 11/00 69/7.5
1,618,183 A *	2/1927	Cutler	A43D 95/22 219/215	2,795,975 A *	6/1957	Stoner	B24D 15/082 76/89.2
1,621,515 A *	3/1927	Merrick	C14B 11/00 12/1 R	2,814,094 A *	11/1957	Hanna	B23D 43/02 407/13
1,630,564 A *	5/1927	Fowler	A43D 95/22 12/42.5	3,043,065 A *	7/1962	Terrel	B24D 13/20 15/230.12
1,730,401 A *	10/1929	Woodcock	A43D 95/24 12/79.5	3,384,913 A *	5/1968	Comeau	A43D 95/22 12/92
1,734,365 A *	11/1929	Collins	C14B 9/00 69/17	3,397,415 A *	8/1968	Keller	A43D 25/06 12/86.65
1,743,183 A *	1/1930	Barclay	A43D 95/22 492/26	3,722,021 A *	3/1973	Brainerd	B01F 35/713 206/229
1,782,802 A *	11/1930	Bazzoni	A43D 95/20 12/77.5	3,952,389 A *	4/1976	Corder	A44C 17/043 29/90.01
1,829,492 A *	10/1931	Rettman	C14B 11/00 69/17	4,118,846 A *	10/1978	Korte	B24B 39/04 29/90.01
1,915,928 A *	6/1933	Harrington	A43D 95/20 118/252	4,127,063 A *	11/1978	Peterson	C14B 1/56 101/316
1,920,253 A *	8/1933	Glass	C14B 11/00 69/7	4,924,576 A *	5/1990	Schiller	C14B 19/00 30/367
1,937,819 A *	12/1933	Hallam	A43D 95/24 12/78	4,993,243 A *	2/1991	Guinn	B23Q 11/06 69/37
1,986,969 A *	1/1935	Booth	A43D 95/24 12/78	5,027,621 A *	7/1991	Schiller	C14B 5/04 83/858
2,177,785 A *	10/1939	Pestel	H03K 4/12 156/254	5,941,101 A *	8/1999	Callo	B24B 9/002 69/17
				2015/0068044 A1 *	3/2015	Watt	B26B 27/00 30/169
				2022/0106650 A1 *	4/2022	Hoffman	C14B 11/00

* cited by examiner

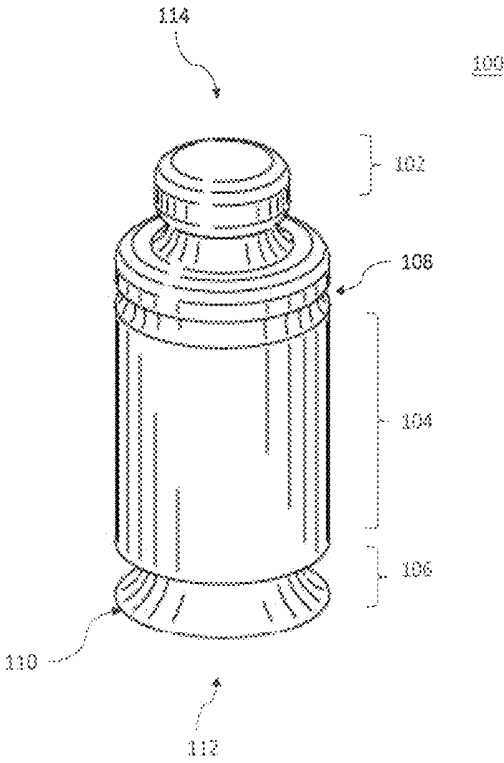

FIG. 1

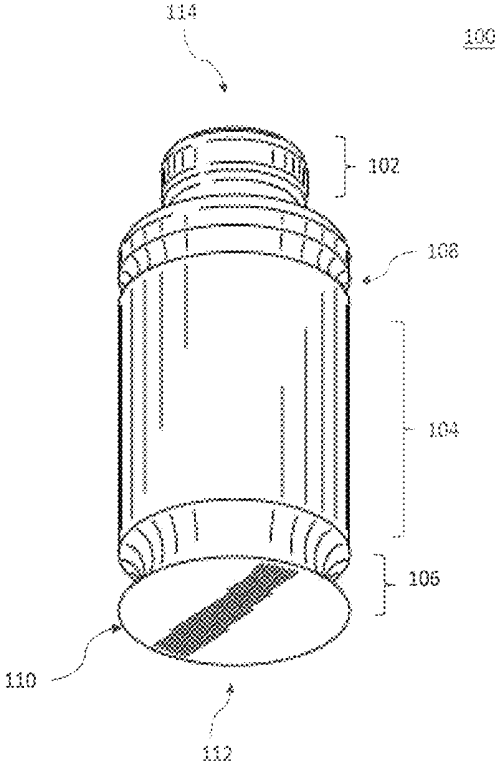
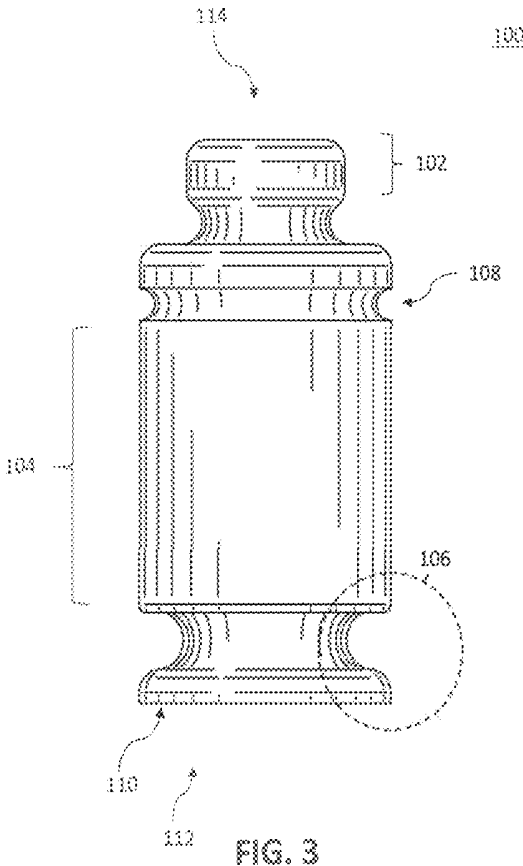

FIG. 2



105

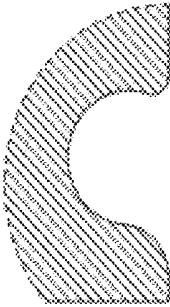

FIG. 4A

106

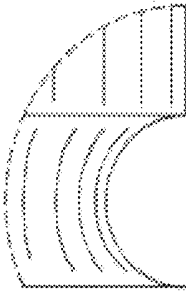

FIG. 4B

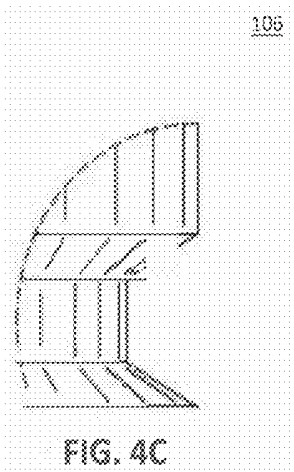

FIG. 4C

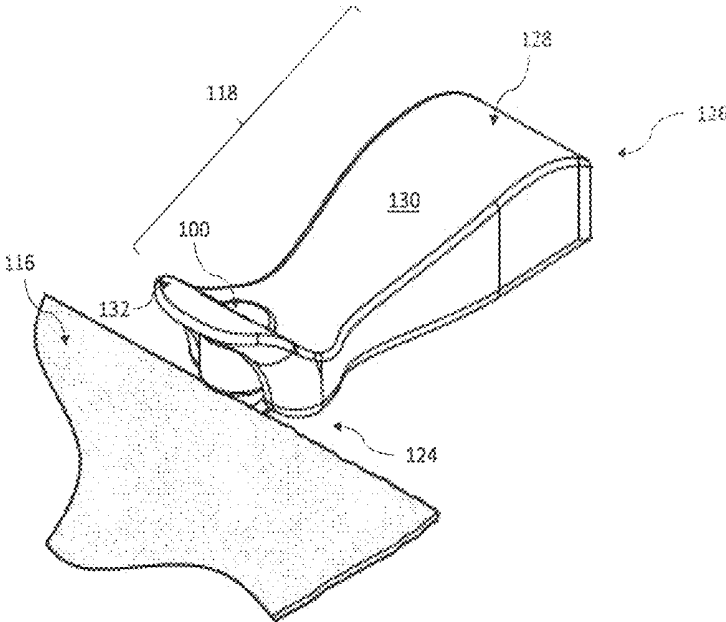

FIG. 5

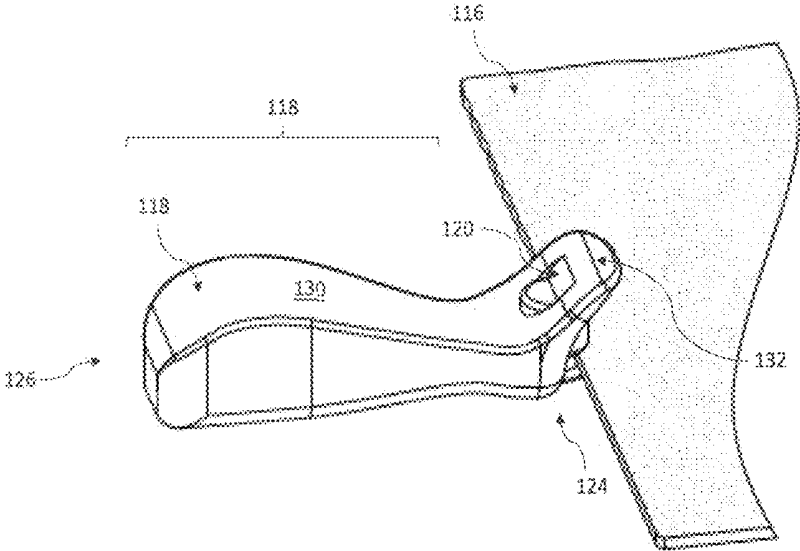

FIG. 6

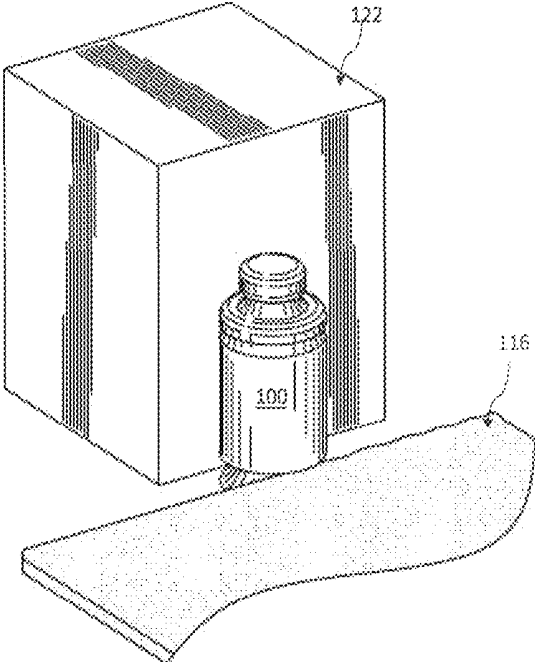

FIG. 7

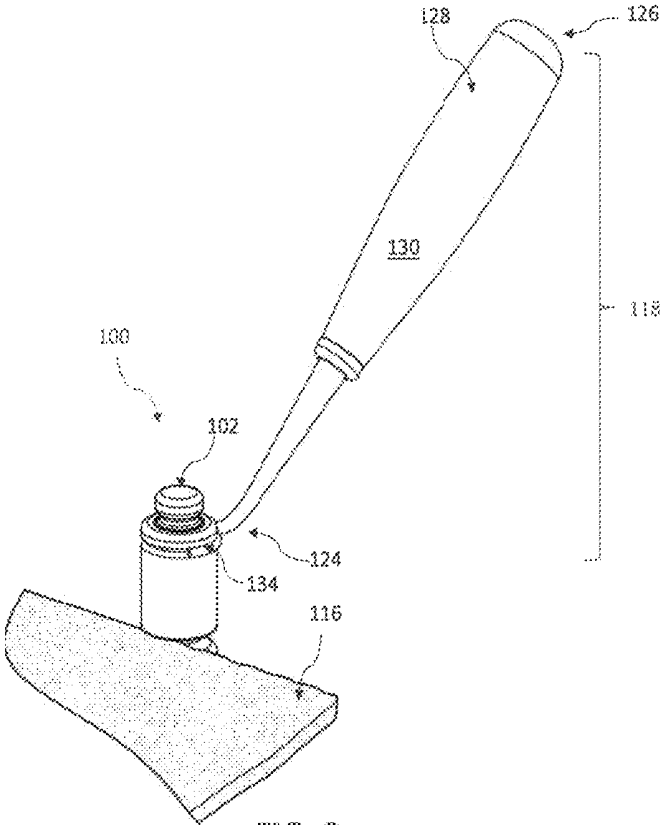

FIG. 8

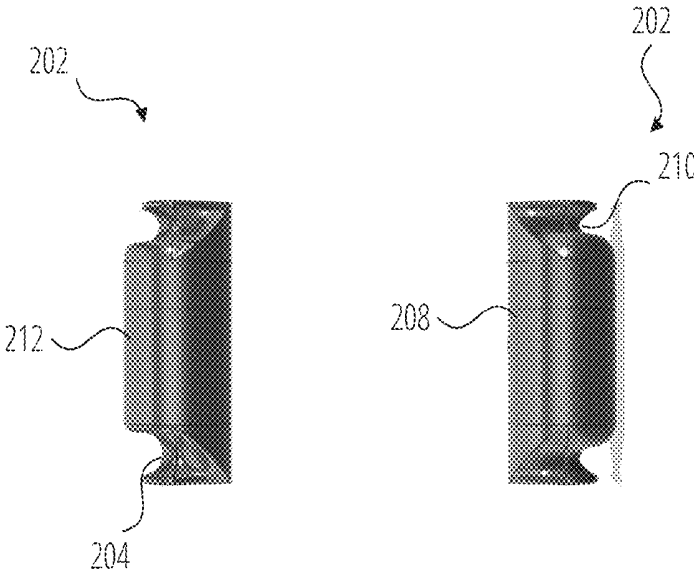

FIG. 9

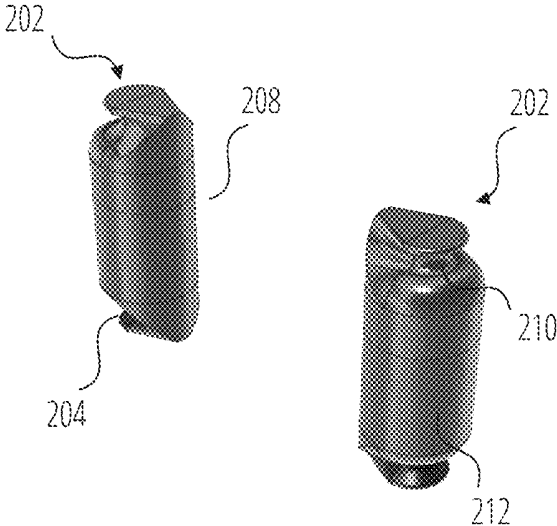

FIG. 10

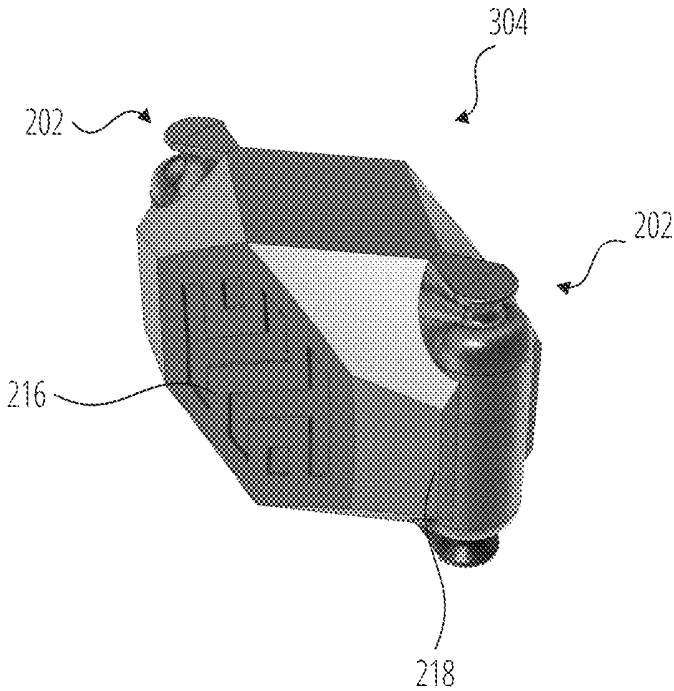

FIG. 11

LEATHER BURNISHING TOOL

FIELD OF THE EMBODIMENTS

The field of the invention and its embodiments relate to leather burnishing tools. In particular, the present invention describes a leather burnishing tool that can be slid along a flat plane or horizontal surface, while maintaining consistent pressure along an edge of a piece of leather to shape and smooth the edge of the piece of leather to a profile of the leather burnishing tool.

BACKGROUND OF THE EMBODIMENTS

When a piece of leather is cut to size or pattern, a raw edge is left that is rough or unfinished in appearance and frequently has a different color than the surface of the material. Various methods may be employed for producing a finished edge to the piece of leather. In some examples, this may occur by skiving the edge of the leather workpiece and then turning over or folding the skived edge, such as what is done in the manufacture of boots and shoes. Another method includes shrinking the flesh side of a piece of leather by applying heat and pressure to the end such that the grain surface of the leather curls to such an extent that it will completely hide the raw edge in the finished work. In other examples, burnishing may be used, which is the process of polishing something, such as leather, by rubbing the leather, resulting in a smooth and shiny surface of the leather.

However, what is needed is an improved leather burnishing tool that can be slid along a flat plane or horizontal surface, while maintaining consistent pressure along an edge of a piece of leather to shape and smooth the edge of the piece of leather to a profile of the leather burnishing tool.

Examples of Related Art

GB 704142 A describes a burnishing tool for finishing the trimmed edges of leather surfaces. U.S. Pat. No. 2,571,149 A describes improvements in or relating to rolling or smoothing devices. U.S. Pat. No. 2,177,785 A describes a method for producing a finished edge for a piece of leather. GB 452433 A describes improvements in or relating to machines for finishing the edges of sheet material, such as leather. GB 663986 A describes a burnishing machine for boots and shoes. U.S. Pat. No. 1,423,052 A describes another leather burnishing tool. CA 443797 A describes a seam-beading process.

Some leather burnishing tools exist in the art. However, their means of operation are substantially different from the present disclosure, as the other inventions fail to solve all the problems taught by the present disclosure.

SUMMARY OF THE EMBODIMENTS

The present invention and its embodiments relate to leather burnishing tools. In particular, the present invention describes a leather burnishing tool that can be slid along a flat plane or horizontal surface, while maintaining consistent pressure along an edge of a piece of leather to shape and smooth the edge of the piece of leather to a profile of the leather burnishing tool.

A first embodiment of the present invention describes a leather burnishing tool. The leather burnishing tool may include a first end disposed opposite a second end. A body portion of the leather burnishing tool is disposed between the first end and the second end. The body portion may be

cylindrical, substantially cylindrical, rectangular, or square in shape. However, it should be appreciated that the shape of the body is not limited to the shapes explicitly described herein.

The first end of the leather burnishing tool includes a first channel and a top portion. The top portion of the leather burnishing tool may include a snap button top portion, for example. The second end of the leather burnishing tool includes a second channel configured to accept an edge of a piece of leather therein and a bottom portion configured to be flush with a horizontal surface or plane.

The second channel of the leather burnishing tool is a polished channel. A size of the second channel is in a range of approximately 1 mm to approximately 6 mm to accommodate thicker cow leather. In preferred examples, the size of the second channel is in the range of approximately 1 mm to approximately 2 mm. In some examples, the second channel of the leather burnishing tool comprises a round shape. In other examples, the second channel of the leather burnishing tool may be any shape. In an illustrative example, the second channel of the leather burnishing tool comprises a hex shape. In other examples, the second channel is flush with the bottom portion. In alternative examples, the second channel comprises a smooth tapered portion such that the second channel is not flush with the bottom portion.

In some examples, the leather burnishing tool may be configured to engage a tool holder. The tool holder includes a first end disposed opposite a second end and a body portion disposed between the first end and the second end. The first end of the tool holder includes an opening that is configured to engage the first channel of the leather burnishing tool to affix the tool holder to the leather burnishing tool. The second end of the tool holder includes a handle component configured to be held in a hand of a user. The tool holder is affixed to the leather burnishing tool via a mechanism, such as a snap button mechanism, a spring clip mechanism, a magnetic mechanism, or an adhesive mechanism, among other examples not explicitly listed herein.

The leather burnishing tool and/or the components of the leather burnishing tool may comprise a plastic material, a metal material, and/or a wood material, among other examples not explicitly listed herein. In examples, a width of the leather burnishing tool is approximately $\frac{1}{4}$ of an inch and a height of the leather burnishing tool is in a range of approximately $\frac{1}{4}$ of an inch to $\frac{1}{2}$ of an inch. In additional examples, the leather burnishing tool is affixed to a fixed object, where the fixed object is flush with a horizontal surface or plane, such as a tabletop.

A second embodiment of the present invention describes a method to use the leather burnishing tool to shape an edge of the piece of leather. The method may include numerous process steps, such as: applying a material to the edge of the piece of leather. The material may be gum tragacanth, beeswax, water, and/or saddle soap, among other materials not explicitly listed herein. In some examples, this process step may not be used. The method may optionally include conditioning the piece of leather with an oil, such as jojoba oil. The method may then include: placing the edge of the piece of leather in the second channel of the leather burnishing tool, such that the bottom portion of the leather burnishing tool is flush with the horizontal surface. Next, the method includes: continuously sliding the leather burnishing tool along the edge of the piece of leather to shape the edge of the piece of leather. In examples where the leather burnishing tool comprises the tool holder, the method may include holding the handle component of the tool holder in a hand of a user while continuously sliding the leather

3

burnishing tool along the edge of the piece of leather to shape the edge of the piece of leather.

In yet another embodiment of the present invention, there is a leather burnishing tool having a body with a first receiving portion and a second receiving portion; and at least one leather burnishing device configured to engage the first receiving portion or the second receiving portion, the at least one leather burnishing device comprising a first burnishing channel, a second burnishing channel, and a burnishing body.

Further, in other embodiments, there is a leather burnishing tool having a body with a first receiving portion and a second receiving portion, wherein the body has one or more planar surfaces; and at least one leather burnishing device configured to engage the first receiving portion or the second receiving portion, the at least one leather burnishing device comprising a first burnishing channel, a second burnishing channel, and a burnishing body, wherein the burnishing body has a first rounded side and a second planar side, wherein the second planar side is configured to engage the first receiving portion or the second receiving portion, and wherein the first burnishing channel and the second burnishing channel have a width that is narrower than a width of the burnishing body.

Even further, there is a leather burnishing tool having a body with a first receiving portion and a second receiving portion, wherein the body has one or more planar surfaces; a first leather burnishing device configured to engage the first receiving portion, the first leather burnishing device comprising a first burnishing channel, a second burnishing channel, and a burnishing body, wherein the burnishing body has a first rounded side and a second planar side, wherein the second planar side is configured to engage the first receiving portion, and wherein the first burnishing channel and the second burnishing channel have a width that is narrower than a width of the burnishing body; and a second leather burnishing device configured to engage the second receiving portion, the second leather burnishing device comprising a first burnishing channel, a second burnishing channel, and a burnishing body, wherein the burnishing body has a first rounded side and a second planar side, wherein the second planar side is configured to engage the second receiving portion, and wherein the first burnishing channel and the second burnishing channel have a width that is narrower than a width of the burnishing body.

BRIEF DESCRIPTION OF THE DRAWINGS

FIG. 1 depicts a schematic diagram of a leather burnishing tool, according to at least some embodiments disclosed herein.

FIG. 2 depicts another schematic diagram of a leather burnishing tool, according to at least some embodiments disclosed herein.

FIG. 3 depicts another schematic diagram of a leather burnishing tool, according to at least some embodiments disclosed herein.

FIG. 4A depicts a schematic diagram of a channel of a leather burnishing tool, according to at least some embodiments disclosed herein.

FIG. 4B depicts a schematic diagram of a first embodiment of a channel of a leather burnishing tool, according to at least some embodiments disclosed herein.

FIG. 4C depicts a schematic diagram of a second embodiment of a channel of a leather burnishing tool, according to at least some embodiments disclosed herein.

4

FIG. 5 depicts a schematic diagram of a first embodiment of a tool holder affixed to a leather burnishing tool, the leather burnishing tool being configured to accept, via a channel, an edge of a piece of leather, according to at least some embodiments disclosed herein.

FIG. 6 depicts another schematic diagram of a first embodiment of a tool holder affixed to a leather burnishing tool, the leather burnishing tool being configured to accept, via a channel, an edge of a piece of leather, according to at least some embodiments disclosed herein.

FIG. 7 depicts a schematic diagram of a leather burnishing tool being affixed to a fixed object, the fixed object being flush with a horizontal surface, where the leather burnishing tool is configured to accept, via a channel, an edge of a piece of leather, according to at least some embodiments disclosed herein.

FIG. 8 depicts a schematic diagram of a second embodiment of a tool holder affixed to a leather burnishing tool, the leather burnishing tool being configured to accept, via a channel, an edge of a piece of leather, according to at least some embodiments disclosed herein.

FIG. 9 depicts an alternative embodiment of a portion of a leather burnishing device.

FIG. 10 depicts an alternative view of the embodiment shown in FIG. 9.

FIG. 11 depicts an alternative leather burnishing tool having removable and/or replaceable leather burnishing devices.

DESCRIPTION OF THE PREFERRED EMBODIMENTS

The preferred embodiments of the present invention will now be described with reference to the drawings. Identical elements in the various figures are identified with the same reference numerals. Reference will now be made in detail to each embodiment of the present invention. Such embodiments are provided by way of explanation of the present invention, which is not intended to be limited thereto. In fact, those of ordinary skill in the art may appreciate upon reading the present specification and viewing the present drawings that various modifications and variations can be made thereto.

A leather burnishing tool **100** may be used to polish something, such as an edge of a piece of leather **116**, by rubbing a portion of the leather burnishing tool **100** against the edge of the piece of leather **116**, resulting in a smooth and shiny surface for the edge of the piece of leather **116**. One such leather burnishing tool **100** is depicted and described herein.

The leather burnishing tool **100** (of FIG. 1, FIG. 2, and FIG. 3) may include a first end **114** disposed opposite a second end **112**. A body portion **104** of the leather burnishing tool **100** is disposed between the first end **114** and the second end **112**. The body portion **104** may be cylindrical (as depicted in FIG. 1, FIG. 2, and FIG. 3), substantially cylindrical, rectangular, or square in shape. It should be appreciated that the shape of the body portion **104** is not limited to those explicitly listed herein.

The first end **114** of the leather burnishing tool **100** includes a first channel **108** and a top portion **102**. In some examples, the first channel **108** of the leather burnishing tool **100** is a spring clip channel. The top portion **102** of the leather burnishing tool **100** may include a snap button top portion, in examples. The second end **112** of the leather burnishing tool **100** includes a second channel **106** config-

ured to accept an edge of a piece of leather **116** therein and a bottom portion **110** flush with a horizontal surface or plane, such as a tabletop.

The second channel **106** of the leather burnishing tool **100** is a polished channel. A size of the second channel **106** is in a range of approximately 1 mm to approximately 6 mm to accommodate thicker cow leather. In preferred examples, the size of the second channel **106** is in the range of approximately 1 mm to approximately 2 mm. In some examples, the size of the second channel **106** is approximately 1 mm. In other examples, the size of the second channel **106** is approximately 1.5 mm. In further examples, the size of the second channel **106** is approximately 2 mm. It should be appreciated that the size of the second channel **106** is not limited to the examples provided herein, as such examples are provided for illustrative purposes only.

The second channel **106** is depicted in a circular broken line in FIG. 3. Various embodiments of the second channel **106** are depicted in FIG. 4A, FIG. 4B, and FIG. 4C. In some examples, the second channel **106** of the leather burnishing tool **100** comprises a round shape (as depicted in FIG. 4A and FIG. 4B). In other examples, the second channel **106** of the leather burnishing tool **100** comprises a hex shape (as depicted in FIG. 4C). In another example, the second channel **106** is flush with the bottom portion **110** (as depicted in FIG. 4B). In alternative examples, the second channel **106** comprises a smooth tapered portion such that the second channel **106** is not flush with the bottom portion **110**.

In some examples, the leather burnishing tool **100** may be configured to engage a tool holder **118** (as depicted in FIG. 5, FIG. 6, and FIG. 8). The tool holder **118** is not limited to the examples described or depicted herein, as the examples are provided for illustrative purposes only. The tool holder **118** includes a first end **124** disposed opposite a second end **126**. The tool holder **118** also includes a body portion **130** disposed between the first end **124** and the second end **126**.

As depicted in FIG. 5 and FIG. 6, the body portion **130** may comprise a slope such that the second end **126** has a greater height than the first end **124**. In some examples and as depicted in FIG. 5 and FIG. 6, the first end **124** may comprise a curved portion **132** that has a height greater than the height of the second end **126**. The first end **124** of the tool holder **118** includes an opening **120** (as depicted in FIG. 6) that is configured to engage the first channel **108** of the leather burnishing tool **100** to affix the tool holder **118** to the leather burnishing tool **100**.

In other examples and as depicted in FIG. 8, the body portion **130** may be substantially cylindrical or cylindrical in shape. As depicted in FIG. 8, the first end **124** of the tool holder **118** has a width smaller than the second end **126** of the tool holder **126**. The first end **124** of the tool holder **118** of FIG. 8 includes a u-shaped component **134** receivable by the first channel **108** of the leather burnishing tool **100** to affix the tool holder **118** to the leather burnishing tool **100**.

The second end **126** of the tool holder **118** includes a handle component **128** (as depicted in FIG. 5, FIG. 6, and FIG. 8). The handle component **128** is configured to be held in a hand of a user. The handle component **128** is not limited to any examples depicted herein, as such examples are provided for illustrative purposes only.

It should be appreciated that the tool holder **118** is affixed to the leather burnishing tool **100** via a mechanism, such as a snap button mechanism, a spring clip mechanism, or an adhesive mechanism, among other examples not explicitly listed herein. In some examples, the leather burnishing tool **100** or a portion of the leather burnishing tool **100** is

magnetic such that the tool holder **118** is affixed to the leather burnishing tool **100** via a magnetic mechanism.

It should be appreciated that the leather burnishing tool **100** and/or the components of the leather burnishing tool **100** may comprise a plastic material, a metal material (such as brass), and/or a wood material, among other examples not explicitly listed herein. In examples, a width of the leather burnishing tool **100** is approximately $\frac{1}{4}$ of an inch and a height of the leather burnishing tool **100** is in a range of approximately $\frac{1}{4}$ of an inch to $\frac{1}{2}$ of an inch. It should be appreciated that the width and height of the leather burnishing tool **100** is not limited to the examples provided herein.

In additional examples, the leather burnishing tool **100** is affixed to a fixed object **122** (as depicted in FIG. 7), where the fixed object **122** is flush with a flat plane or a horizontal surface, such as a tabletop. In examples, the fixed object **122** is a block of wood and the leather burnishing tool **100** is affixed to the fixed object **122** via an adhesive.

A method to use the leather burnishing tool **100** described herein to shape an edge of the piece of leather **116** may include numerous process steps, such as: applying a material to the edge of the piece of leather **116**. The material may be gum tragacanth, beeswax, water, and/or saddle soap, among other materials not explicitly listed herein. The method may optionally include conditioning the edge of the piece of leather **116** with an oil, such as jojoba oil.

The method may then include: placing the edge of the piece of leather **116** in the second channel **106** of the leather burnishing tool **100**, such that the bottom portion **110** at the second end **122** of the leather burnishing tool **100** is flush with the flat plane or the horizontal surface. The method then includes: continuously sliding the leather burnishing tool **100** along the edge of the piece of leather **116** to shape the edge of the piece of leather **116**. Such continuous sliding creates friction to burnish the edge of the piece of leather **116**. Further, sliding the leather burnishing tool **100** along the flat plane or the horizontal surface maintains consistent pressure along the edge of the piece of leather **116**, smoothing the edge of the piece of leather **116** to the profile of the leather burnishing tool **100**.

In examples where the leather burnishing tool **100** comprises the tool holder **118**, the method may include holding the handle component **128** of the tool holder **118** in a hand of a user while continuously sliding the leather burnishing tool **100** along the edge of the piece of leather **116** to shape the edge of the piece of leather **116**.

It should further be appreciated that in some examples, the leather burnishing tool **100** may be heated via an external source of heat (such as a heating pad or a heating gun, among other examples). In further examples, the leather burnishing tool **100** may be heated with a mini-heating element that is affixed to a holder or is present inside of the leather burnishing tool **100**.

As shown in FIGS. 9-11, there is another embodiment of the present invention. Here there is a central body **304** which has one or more planar surfaces **216**. Preferably, the planar surfaces **216** allow a user to grip the central body **304** or otherwise secure a position of the central body **304**. The central body **304** may be hollow or solid in construction. Preferred materials may be polymers such as but not limited to polyethylene terephthalate (PET), polyethylene (PE), high-density polyethylene, polyvinyl chloride (PVC), polyvinylidene chloride (PVDC), low-density polyethylene (LDPE), polypropylene (PP), polystyrene (PS), high impact polystyrene (HIPS) and polycarbonate (PC), or any combination thereof. Other materials such as composites, woods or hardwoods, and certain metals may also be used. Compos-

ites may include but are not limited to fiber-reinforced plastics, metal composites, carbon fiber, Kevlar® and the like. Metals may comprise lightweight metals such as aluminum and other pure metals as well as various alloys.

The central body **304** further has receiving portions **218**. There may be one or more receiving portions **218** in the central body **304**. In some embodiments, there are more receiving portions **218** than the two shown in FIG. **11**. Each receiving portion **218** may be substantially similar or different (height, length, width, curvature, etc.) than any other receiving portions present in the central body **304**. Each receiving portion **218** may be generally semi-circular with wings or protrusions that emanate from the central body **304**. These protrusions allow for the receiving portions to selectively retain the leather burnishing device(s) **202** associated with the present embodiment. In a preferred embodiment, the receiving portions **218** frictionably engage the leather burnishing devices **202**. However, other mechanisms of adherence generally known in the art may also be employed to achieve the same end result. The receiving portions **218** should generally be shaped and configured to allow the leather burnishing devices **202** to be removable from the receiving portions **218** thereby lending variety and modularity to the device as a whole.

The leather burnishing devices **202** are shaped to engage and, on at least one surface, fit into the receiving portions **218** and sit flush with a rear of the receiving portions **218**. As shown in FIGS. **9** and **10**, the leather burnishing devices **202** have a first side **212**, second side **208**, first burnishing channel **204** and a second burnishing channel **210**. Each of the two leather burnishing devices **202** as shown are substantially identical. However, the central body **304** may be selectively joined with any configuration of leather burnishing devices under the purview of the present invention.

Each leather burnishing device **202** has a height and a width and is preferably comprised of a metal or other material suitable to shape or burnish leather. At or near a top of the leather burnishing device **202** is a first burnishing channel **210** and at or near a bottom of the leather burnishing device **202** is a second burnishing channel **204**. Each of the two burnishing channels may be dimensionally identical or different from one another. Preferably each burnishing channel has a smooth arcuate shape that allows for the shaping of leather. In at least one embodiment it is preferable to have one channel configured for rough burnishing and another channel configured for fine burnishing.

Positioned between the first burnishing channel **210** and the second burnishing channel **204** is a burnishing body having a first surface **212** and a second surface **208**. The first surface **212** may be more arcuate than the second surface **208** which may be more planar. However, the first surface **212** is generally shaped to be aesthetically pleasing and not obstruct access to the burnishing channels and second surface **208** primarily serves to engage and be retained by the receiving portion **218**. A height of the burnishing body can vary depending on the dimensions of the central body **304** and the intended use of the burnishing tool as a whole. In each instance, the first burnishing channel **210** and the second burnishing channel **204** have a width that is less than a width of the burnishing body.

In practice, the central body **304** is preferably positioned on a surface with one or more leather burnishing devices **202** inserted into the one or more receiving portions **218**. A piece of leather may then be passed through the first burnishing channel **210** and/or the second burnishing channel **204** a number of times until the desired edge is formed on the leather. In other embodiments, the leather may remain

stationary while the leather burnishing device is held in hand and passed along the leather one or more times until the desired edge is formed on the leather.

It is to be noted that the descriptions of the various embodiments of the present invention have been presented for purposes of illustration, but are not intended to be exhaustive or limited to the embodiments disclosed. Many modifications and variations will be apparent to those of ordinary skill in the art without departing from the scope and spirit of the described embodiments. The terminology used herein was chosen to best explain the principles of the embodiments, the practical application or technical improvement over technologies found in the marketplace, or to enable others or ordinary skill in the art to understand the embodiments disclosed herein.

When introducing elements of the present disclosure or the embodiments thereof, the articles “a,” “an,” and “the” are intended to mean that there are one or more of the elements. Similarly, the adjective “another,” when used to introduce an element, is intended to mean one or more elements. The terms “including” and “having” are intended to be inclusive such that there may be additional elements other than the listed elements.

Although this invention has been described with a certain degree of particularity, it is to be understood that the present disclosure has been made only by way of illustration and that numerous changes in the details of construction and arrangement of parts may be resorted to without departing from the spirit and the scope of the invention.

What is claimed is:

1. A leather burnishing tool comprising:

a body having a first receiving portion and a second receiving portion; and

at least one leather burnishing device configured to engage the first receiving portion or the second receiving portion,

the at least one leather burnishing device comprising a top end, a bottom end, a first rounded side extending between the top end and the bottom end, and a second planar side extending between the top end and the bottom end;

the first rounded side comprising a first burnishing channel located adjacent the top end, a second burnishing channel located adjacent the bottom end, and a burnishing body in between the first and second burnishing channels;

wherein the second planar side engages the first receiving portion or the second receiving portion such that the second planar side is flush with the first receiving portion of the second receiving portion.

2. The leather burnishing tool of claim **1** wherein the first burnishing channel and the second burnishing channel have a width that is narrower than a width of the burnishing body.

3. The leather burnishing tool of claim **1** wherein the at least one burnishing device comprises a first burnishing device and a second burnishing device, the first burnishing device engaging the first there are two leather burnishing devices with one leather burnishing device engaging the first burnishing channel receiving portion and the second another leather burnishing device engaging the second burnishing channel receiving portion.

4. The leather burnishing tool of claim **1** wherein the body has one or more planar surfaces.

5. A leather burnishing tool comprising:

a body having a first receiving portion and a second receiving portion,

wherein the body has one or more planar surfaces; and

9

at least one leather burnishing device configured to engage the first receiving portion or the second receiving portion,

the at least one leather burnishing device comprising a first rounded side and a second planar side, the first rounded side comprising a first burnishing channel, a second burnishing channel, and a burnishing body, wherein the burnishing body has a first rounded side and a second planar side,

wherein the second planar side is configured to engage the first receiving portion or the second receiving portion such that the second planar side is flush with the first receiving portion of the second receiving portion, and wherein the first burnishing channel and the second burnishing channel have a width that is narrower than a width of the burnishing body.

6. The leather burnishing tool of claim 5 wherein the first receiving portion and the second receiving portion are semi-circular each have wings that emanate from a central portion of the body.

7. The leather burnishing tool of claim 5 wherein the first receiving portion and the second receiving portion span a height of the body.

8. The leather burnishing tool of claim 5 wherein the at least one burnishing device comprises a first burnishing device and a second burnishing device, the first burnishing device engaging the first receiving portion and the second burnishing device engaging the second receiving portion.

9. A leather burnishing tool comprising:
a body having a first receiving portion and a second receiving portion, the first receiving portion and the

10

second receiving portion each comprising wings that emanate from a central portion of the body, wherein the body has one or more planar surfaces;

a first leather burnishing device configured to engage the first receiving portion, the first leather burnishing device comprising a first burnishing channel, a second burnishing channel, and a burnishing body, wherein the burnishing body has a first rounded side and a second planar side, wherein the second planar side is configured to engage the first receiving portion, and wherein the first burnishing channel and the second burnishing channel have a width that is narrower than a width of the burnishing body.

10. The leather burnishing tool of claim 9, further comprising a second leather burnishing device configured to engage the second receiving portion,

the second leather burnishing device comprising a first burnishing channel, a second burnishing channel, and a burnishing body,

wherein the burnishing body of the second leather burnishing device has a first rounded side and a second planar side,

wherein the second planar side of the second leather burnishing device is configured to engage the second receiving portion, and

wherein the first burnishing channel of the second leather burnishing device and the second burnishing channel of the second leather burnishing device have a width that is narrower than a width of the burnishing body of the second leather burnishing device.

* * * * *