



(43) International Publication Date
18 November 2021 (18.11.2021)

(51) International Patent Classification:

G09B 9/00 (2006.01) F41A 33/02 (2006.01)
G06F 3/01 (2006.01) F41G 3/26 (2006.01)

(21) International Application Number:

PCT/US2021/032375

(22) International Filing Date:

14 May 2021 (14.05.2021)

(25) Filing Language:

English

(26) Publication Language:

English

(30) Priority Data:

16/875,379 15 May 2020 (15.05.2020) US

(71) Applicant: **V-ARMED INC.** [US/US]; 1001 Avenue of The Americas, 24th Floor, New York, NY 10018 (US).

(72) Inventors: **KUR, Daniel**; 3035 Llomar Court, Mississauga, ON L5N 5B6 (CA). **DABUSH, Elad**; 487 West End Avenue, Apt #5B, New York, NY 10024 (US).

(74) Agent: **POSTOLSKI, David**; Gearhart Law LLC, 41 River Road, Innovation Plaza, Suite 1A, Summit, NJ 07901 (US).

(81) Designated States (unless otherwise indicated, for every kind of national protection available): AE, AG, AL, AM, AO, AT, AU, AZ, BA, BB, BG, BH, BN, BR, BW, BY, BZ, CA, CH, CL, CN, CO, CR, CU, CZ, DE, DJ, DK, DM, DO, DZ, EC, EE, EG, ES, FI, GB, GD, GE, GH, GM, GT, HN,

HR, HU, ID, IL, IN, IR, IS, IT, JO, JP, KE, KG, KH, KN, KP, KR, KW, KZ, LA, LC, LK, LR, LS, LU, LY, MA, MD, ME, MG, MK, MN, MW, MX, MY, MZ, NA, NG, NI, NO, NZ, OM, PA, PE, PG, PH, PL, PT, QA, RO, RS, RU, RW, SA, SC, SD, SE, SG, SK, SL, ST, SV, SY, TH, TJ, TM, TN, TR, TT, TZ, UA, UG, US, UZ, VC, VN, WS, ZA, ZM, ZW.

(84) Designated States (unless otherwise indicated, for every kind of regional protection available): ARIPO (BW, GH, GM, KE, LR, LS, MW, MZ, NA, RW, SD, SL, ST, SZ, TZ, UG, ZM, ZW), Eurasian (AM, AZ, BY, KG, KZ, RU, TJ, TM), European (AL, AT, BE, BG, CH, CY, CZ, DE, DK, EE, ES, FI, FR, GB, GR, HR, HU, IE, IS, IT, LT, LU, LV, MC, MK, MT, NL, NO, PL, PT, RO, RS, SE, SI, SK, SM, TR), OAPI (BF, BJ, CF, CG, CI, CM, GA, GN, GQ, GW, KM, ML, MR, NE, SN, TD, TG).

Published:

— with international search report (Art. 21(3))



WO 2021/231815 A1

(54) Title: FULL-BODY INVERSE KINEMATIC (FBIK) MODULE FOR USE IN FIREARM SIMULATION TRAINING

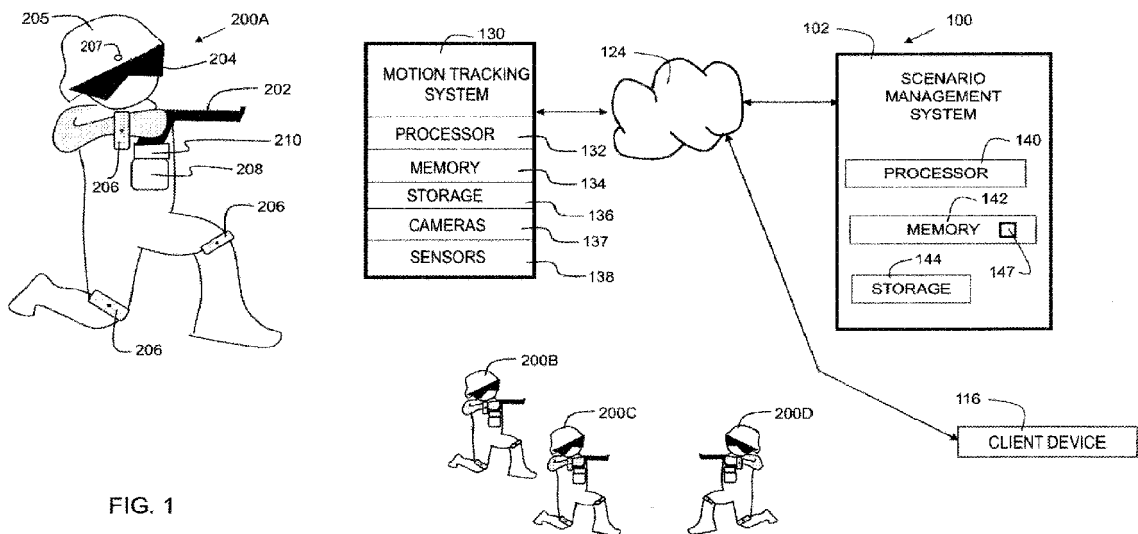

FIG. 1

(57) Abstract: A Full-Body Inverse Kinematic (FBIK) module for use in tracking a user in a virtual reality (VR) environment. The FBIK module has an enclosure containing a power source, a plurality of active tags with lights for use by a motion tracking system to track the user, and a controller that flashes the lights in distinct patterns to identify the user of the FBIK module.

**FULL-BODY INVERSE KINEMATIC (FBIK) MODULE FOR USE IN FIREARM
SIMULATION TRAINING**

5

CROSS-REFERENCE TO RELATED APPLICATIONS

[0001] The present application is a PCT Patent Application that claims priority to U.S. Non-Provisional Application No. 16/875,379, filed May 15, 2020, the entire contents of which
10 are being incorporated herein by reference.

FIELD OF THE EMBODIMENTS

[0002] Disclosed embodiments relate to firearm simulation and training, and more particularly to
15 firearm simulation and training utilizing motion tracking.

BACKGROUND

[0003] Military training programs of the US Armed Forces are vital for mission success. Military
training, aimed at the accomplishment of tasks associated with a military mission, is an
important part of troop readiness. Without proper training, soldiers may be unprepared for
20 an actual battle. Similarly, law enforcement personnel benefit from training for various
situations they may encounter during their patrols. In law enforcement, personnel may not
have much advance notice of when they will be in a dangerous situation. Thus, periodic
training exercises are important for law enforcement to maintain a state of readiness. It is
therefore desirable to have improvements in the training of military and law enforcement
25 personnel.

SUMMARY OF THE EMBODIMENTS

[0004] In an embodiment, there is provided a Full-Body Inverse Kinematic (FBIK) module for use
in tracking a user in a virtual reality (VR) environment. The FBIK module comprises an
30 enclosure containing a power source; a plurality of active tags, each tag having a light for
use by a motion tracking system to track the user of the FBIK module; and a controller that

flashes the lights in distinct patters identifiable by the motion tracking system to identify the user of the FBIK module.

5 [0005] In an embodiment, the FBIK module enclosure is configured to be coupled to a wearable adjustable strap fitted to the user. The strap may include a pocket configured to receive the FBIK module. The FBIK module enclosure may be in the form of a rigid puck that protects its contents and is configured to be removably inserted into the pocket. The pocket may contain a base plate configured with the puck to include a locking mechanism that secures the puck to the base plate in the pocket.

10 [0006] In an embodiment, the FBIK module active tag lights radiate at a frequency not visible by the human eye, but visible to a least one camera of the motion tracking system. The FBIK module may include a light controller that flashes the lights in distinct patterns that can be identified by the motion tracking system.

15 [0007] In an embodiment, the motion tracking system triangulates the FBIK module's active markers' positions in 6 degrees of freedom to determine the markers' location and relative orientation within a 3D space of the VR environment.

[0008] In an embodiment, the FBIK module is one of a plurality of substantially similar FBIK modules worn on the extremities of a user. The motion tracking system triangulates the positions of all of the active markers of the FBIK modules worn by the user, and determines from the tags' positions at least one of a movement, an orientation, and a posture of the user.

20 [0009] In an embodiment, the FBIK module power source is a battery. The battery may be contained within the enclosure, which has a charging port to couple the enclosed battery to a charging source. Or, the battery may be external to the enclosure, which has a battery port to couple the external battery to the enclosure.

25 [0010] In an embodiment, the FBIK module may comprise one or more inertial measurement units (IMUs) that compensate for loss of visibility of one or more of the markers when they are occluded by an object between the FBIK module and a camera of the tracking system. The IMU uses information obtained from at least one of an accelerometer, a gyroscope, and a magnetometer to determine extremity information. The extremity information includes at least one of a force, a linear motion, an angular motion, a momentum, an acceleration, and an orientation, of a user's extremity on which the FBIK module is worn. In this
30 embodiment, the FBIK module comprises a transmitter to wirelessly transmit at least a

portion of the extremity information to the motion tracking system for keeping track of the markers when they are occluded from a system camera by an object in the VR environment.

[0011] In an embodiment, the motion tracking system combines information obtained from the FBIK module with information obtained from at least one of a backpack tracker and a head
5 mounted display tracker to more accurately track the user.

[0012] In an embodiment, T-Pose calibration information of the user is used by a scenario management system to render an avatar of the user for display to other users in the VR environment.

10

BRIEF DESCRIPTION OF THE DRAWINGS

[0013] FIG. 1 is a diagram of a system in accordance with embodiments of the present invention.

[0014] FIG. 2 is a diagram of a client device in accordance with embodiments of the present invention.

15

[0015] FIG. 3 is a block diagram of components in accordance with embodiments of the present invention.

[0016] FIGs. 4A – 4D show a shock mount in accordance with embodiments of the present invention.

[0017] FIGs. 5A, 5B, and 5C illustrate examples of a shock mount in use.

20

[0018] FIG. 6 illustrates a weapon simulator in accordance with embodiments of the present invention.

[0019] FIG. 7 illustrates a weapon simulator in accordance with additional embodiments of the present invention.

[0020] FIG. 8A – 8I illustrate examples of inverse kinematic solver computations.

25

[0021] FIG. 9A is a front view of a wearable sensor in accordance with embodiments of the present invention.

[0022] FIG. 9B is a rear view of the wearable sensor of FIG. 9A.

[0023] FIG. 10 is a flowchart indicating process steps for embodiments of the present invention.

[0024] FIG. 11 is a flowchart indicating additional process steps for embodiments of the present invention.

30

[0025] FIG. 12 is an exemplary user interface in accordance with embodiments of the present invention.

[0026] FIG. 13 shows an additional embodiment of a weapon simulator.

[0027] FIG. 14 illustrates an exemplary embodiment of a full body inverse kinematic (FBIK) module.

[0028] FIGs. 15A and 15B show perspective views of an embodiment of an FBIK module.

5 [0029] FIG. 16 shows the steps of an exemplary method for performing calibration and refinement of data pertaining to a person being tracked.

[0030] The structure, operation, and advantages of disclosed embodiments will become further apparent upon consideration of the following description taken in conjunction with the accompanying figures (FIGs.). The figures are intended to be illustrative, not limiting. Certain elements in some of the figures may be omitted, or illustrated not-to-scale, for
10 illustrative clarity.

DETAILED DESCRIPTION

[0031] Disclosed embodiments provide systems and methods for conducting a firearm usage simulation including simulated firearm discharge, enabling enhanced training of armed
15 forces and/or law enforcement personnel. A motion tracking system tracks motion of one or more users. In embodiments, the users wear one or more sensors, transponders, or other wearable devices on their bodies to allow tracking by the motion tracking system. A scenario management system utilizes position, orientation, and motion information provided by the motion tracking system to evaluate user performance during a scenario. A weapon
20 simulator includes sensors that indicate position of the weapon and/or orientation of the weapon. The weapon simulator may further provide trigger activation indications to the scenario management system. In embodiments, the scenario management system generates, plays, reviews, and/or evaluates simulations. The evaluation can include scoring based on reaction times, posture, body position, body orientation, and/or other attributes. Thus,
25 disclosed embodiments provide a safe and cost-effective way to train personnel in the use of a weapon in various scenarios, and evaluate the users based on information provided by the motion tracking system and/or weapon simulator.

[0032] FIG. 1 is a diagram of a system 100 in accordance with embodiments of the present invention. System 100 includes a scenario management system 102. The scenario
30 management system 102 can be implemented in an electronic computing device that includes a processor 140, a memory 142 coupled to the processor, and storage 144, also coupled to the processor 140. Memory 142 contains instructions 147, that when executed by

the processor 140, cause the scenario management system 102 to perform steps in accordance with embodiments of the present invention. Memory 142 may be a non-transitory computer readable medium. Memory 142 may include, but is not limited to, flash, read-only memory (ROM), static random-access memory (SRAM), magnetic storage, optical storage, or other suitable storage mechanism. Storage 144 may include one or more magnetic hard disk drives (HDD), solid state disk drives (SSD), optical storage devices, tape drives, and/or other suitable storage devices.

[0033] In embodiments, storage 144 may include multiple hard disk drives configured in a RAID (redundant array of independent disks) configuration. In embodiments, the RAID configuration can include a RAID 1 configuration in which data is copied seamlessly and simultaneously, from one disk to another, creating a replica, or mirror. If one hard disk drive becomes inoperable, another hard disk drive continues to operate, providing a level of fault tolerance.

[0034] The processor 140 may include multiple cores. In embodiments, the scenario management system 102 may include multiple processors, where each processor includes multiple cores. Embodiments may schedule tasks and threads over multiple processors and/or cores to achieve a level of parallelism in execution of various tasks such as computations, rendering, and/or scenario generation.

[0035] Embodiments may include additional redundancy through failover mechanisms. In embodiments, the scenario management system 102 may be instantiated as a virtual machine operating in a cloud environment. In embodiments, multiple instantiations of the scenario management system 102 may be implemented in the cloud environment. Scenario management system 102 is in communication with network 124. Network 124 may be the Internet, a local area network (LAN), wide area network (WAN), or another suitable network.

[0036] The term "Internet" as used herein refers to a network of networks which uses certain protocols, such as the TCP/IP protocol, and possibly other protocols such as the hypertext transfer protocol (HTTP) for hypertext markup language (HTML) documents that make up the World Wide Web (web). The physical connections of the Internet and the protocols and communication procedures of the Internet are well known to those of skill in the art. Access to the Internet can be provided by Internet service providers (ISP). Users on client systems, such as client 116 obtains access to the Internet through the Internet service providers.

Access to the Internet allows users of the client computer systems to exchange information, receive and send e-mails, and view documents, such as documents which have been prepared in the HTML format. These documents are often provided by web servers which are considered to be "on" the Internet. Often these web servers are provided by the ISPs, although a computer system can be set up and connected to the Internet without that system being also an ISP as is well known in the art.

[0037] System 100 further includes motion tracking system 130. Motion tracking system 130 includes a processor 132, a memory 134 coupled to the processor, and storage 136, also coupled to the processor 132. Memory 134 contains instructions, that when executed by the processor 132, cause the motion tracking system 130 to perform steps in accordance with embodiments of the present invention. Memory 134 may be a non-transitory computer readable medium. Memory 134 may include, but is not limited to, flash, read-only memory (ROM), static random-access memory (SRAM), magnetic storage, optical storage, or other suitable storage mechanism. Storage 136 may include one or more magnetic hard disk drives (HDD), solid state disk drives (SSD), optical storage devices, tape drives, and/or other suitable storage devices. In embodiments, memory 134 includes at least 32 gigabytes of RAM. Motion tracking system 130 further includes one or more cameras 137. The cameras may be configured to detect visible and/or infrared light. The motion tracking system 130 may further include one or more sensors. These sensors may include, but are not limited to, temperature sensors, proximity sensors, noise sensors, and/or other suitable sensors. In some embodiments, processor 132 may include an Intel i7 CPU or higher. The motion tracking system 130 may include a graphics processor such as the Nvidia GTX 1070 or higher, and include a high-performance network card.

[0038] A client device, indicated as 116 may be connected to network 124 via a wired or wireless interface. Client device 116 may include a mobile computing device such as a smartphone or tablet, a laptop computer, a desktop computer, or other suitable computing device. The client-server architecture allows a user to remotely access features of the scenario management system 102. In embodiments, the client device 116 may include an Intel i7 CPU or higher, an Nvidia GTX 1080 graphics processing unit or higher, and 16 GB of ram or more.

[0039] Embodiments of the present invention may utilize a JavaScript Object Notation (JSON) web service to make a JSON call to the scenario management system. In some examples, the

JSON call is made using XML HTTP, which implements an XML HTTP object that has functionality enabling the exchange of Extensible Markup Language (XML) data directly over the Internet using the Hypertext Transfer Protocol (HTTP). The XML HTTP object allows access of the scenario management system data from a server, parsing the data using
5 an XML Document Object Model (DOM), and posting XML data through a standard firewall directly to an HTTP server.

[0040] The cameras 137 and/or sensors 138 of motion tracking system 130 may be deployed in a venue such as a room, building, or outdoor area, such that they can track the motion of one or more users (200A, 200B, 200C, and 200D). Note that while four users are shown in FIG.
10 1, in practice, more or fewer users may be present. Referring now to user 200A, additional detail is shown. Each user may utilize one or more wearable sensors 206. The wearable sensors can be used to detect motion and position of a user. By having sensors on the limbs of a user, the position and/or orientation of a user can be more precisely determined. Each user may further wear a helmet 205. The helmet 205 may include a sensor 207 that can be
15 used to determine head location and/or head orientation of the wearer (user). Each user may further wear goggles 204. The goggles 204 may include virtual reality goggles, augmented reality goggles, or other suitable eyewear. The goggles 204 may further include speakers that provide audible feedback to a user. In embodiments, the goggles 204 may include a forward-facing camera to enable recording and/or monitoring of the user's point of view. In
20 embodiments, the goggles 204 may include a user-facing camera to monitor the eye gaze of a user. In this way, the direction of eye gaze, even if different from head orientation, can be ascertained.

[0041] Each user may further utilize a weapon simulator 202. The weapon simulator may be in the form of a firearm, and may include a recoil simulation mechanism such as compressed air or
25 a mechanical spring to simulate the recoil associated with discharging a real firearm. The weapon simulator 202 may further include an inertial tracker 208 affixed to the weapon simulator 202. The inertial tracker 208 may include one or more accelerometers and/or gyroscopes to track motion of the weapon simulator 202. Sometimes, motion associated with recoil can adversely affect the inertial tracker 208. Therefore, embodiments may
30 further include a shock mount 210 disposed between the weapon simulator 202 and the inertial tracker 208. This allows the position of the weapon simulator to be tracked as the

user moves it, while preventing the adverse effects of recoil motion, since the shock mount absorbs some of the recoil motion.

[0042] FIG. 2 is a block diagram of a client device 300 in accordance with embodiments of the present invention. In embodiments, client device 300 is an electronic device that may include a desktop computer, laptop computer, tablet computer, smartphone, and/or other suitable client device. Client device 300 may be similar to client device 116 as shown in FIG. 1. Client device 300 includes a processor 302, a memory 304 coupled to the processor 302, and storage 306. The memory 304 may be a non-transitory computer readable medium. Memory 304 may include RAM, ROM, flash, EEPROM, or other suitable storage technology. The memory 304 contains instructions, that when executed by processor 302, enable communication to/from scenario management system 102 of FIG. 1. Client device 300 further includes a network communication interface 310 for performing this communication. In embodiments, network communication interface 310 includes a wireless communications interface such as a cellular data interface and/or a Wi-Fi interface. In embodiments, the storage 306 includes flash, SRAM, one or more hard disk drives (HDDs) and/or solid state disk drives (SDDs).

[0043] Device 300 may further include a user interface 308. User interface 308 may include a keyboard, monitor, mouse, and/or touchscreen, and provides a user with the ability to enter information as necessary to utilize embodiments of the present invention. In embodiments, a user uses the device 300 to access the scenario management system 102.

[0044] FIG. 3 is a block diagram 400 of components in accordance with embodiments of the present invention. Components include, but are not limited to, motion tracker 402, weapons interface 404, inverse kinematic solver 406, client communication component 408, scenario management component 410, and/or data analysis 412. The motion tracker 402 may be a commercially available motion tracker such as OptiTrack™ by NatrualPoint, of Corvallis, Oregon. The motion tracker 402 may include multiple cameras installed within a room, building, or other venue where a scenario is to be executed. The cameras may be adapted to track wearable sensors that emit infrared light. As a user, wearing the wearable sensors moves, his/her motion is tracked by the motion tracker 402. The weapons interface 404 may implement recoil simulation, gun flash simulation, trigger activation notifications, and/or other weapons-related simulation functions. The inverse kinematic (IK) solver 406 may be used to create an inverse kinematic solution to rotate and position links in a chain. This can

be used to model human movement to create virtual targets and/or model the motion of live users.

[0045] The scenario management component 410 may be implemented as a computer system such as system 102 of FIG. 1. Alternatively, the scenario management component 410 may be implemented as multiple computers in a distributed or cloud computing environment. The scenario management component may be used for generating scenarios, executing scenarios, and/or playback of previously executed scenarios. The data analysis component 412 may be used for analyzing an executed scenario. This can include performing numerous assessments on users that are tracked by the motion tracker 402. Assessments can include reaction time, location analysis, physiological orientation of the user, orientation of the user's head, eye gaze, limb position, and others.

[0046] For example, in a given scenario, upon hearing a gunshot, a user may be trained to drop to a crouched position, turn his head towards the direction of the gunshots, and draw his weapon. To provide a training experience for a user, a scenario is executed by the scenario management component 410. This component may generate the virtual environment, including audiovisual information rendered by goggles 204. A gunshot sound is rendered on the speaker of goggles 204 worn by the user, and the scenario management component 410 records this time. The user starts to move, and the motion tracker determines how long it takes to get into a crouched position, how long it takes for the user to draw his weapon, and if his head is oriented in the proper position. In embodiments, after a predetermined time (e.g. 2 seconds), the user orientation and weapon orientation are evaluated. In embodiments, a user score is generated based on the time required for the user to achieve the proper position. In this way, the user can continually practice, and review his performance to achieve an optimal reaction time. Other, more complex examples are possible, such as scenarios utilizing multiple friends and foes. In embodiments, one or more of the friends and/or foes may be virtual.

[0047] FIG. 4A – 4D show a shock mount in accordance with embodiments of the present invention.

[0048] FIG. 4A is a perspective view of a shock mount 500 in accordance with embodiments of the present invention. Shock mount 500 includes a top plate 503, a bottom plate 506, and a plurality of resilient members 504 configured and disposed between the top plate 503 and the bottom plate 506, and terminated at the top with end caps, indicated generally as 541.

This reduces the amount of shock imparted to the inertial tracker 508 from the handle 526 of a weapon simulator as a result of a recoil simulation. The weapon simulator may utilize compressed air, solenoids, springs, or other electromechanical mechanisms to simulate a recoil that occurs when a firearm is discharged. The shock mount 500 reduces the shock
5 imparted on the inertial tracker 508, which helps improve the reliability of data returned by the inertial tracker. In embodiments, the inertial tracker may be a commercially available inertial tracker such as Vive™ tracker by HTC corporation. In some embodiments, the resiliency of the resilient members 504 may be adjustable to accommodate different types of weapon simulators and/or inertial trackers. Shock mount 500 may be similar to shock
10 mount 210 shown in FIG. 1. FIG. 4B is a top view of the shock mount 500, illustrating the mounting shoe 543 configured and disposed to receive a weapon simulator. FIG. 4C is a front view of the shock mount 500, illustrating a plurality of coupling pins 545 for interfacing to an inertial tracker. In embodiments, the coupling pins 545 may be spring loaded “Pogo” pins. FIG. 4D is a bottom view of the shock mount 500, indicating a linear
15 arrangement of the coupling pins 545.

[0049] FIG. 5 illustrates an example of a shock mount in use. A weapon simulator 520 has a handle 526. In embodiments, the weapon simulator 520 may be in the form factor of a pistol. The shock mount 500 is affixed to the bottom of the handle (grip) 526. The inertial tracker 508 is affixed to the shock mount 500. The weapon simulator 520 shown is a Glock simulator.
20 In embodiments, the weapon simulator 520 is configured to use compressed gas in order to create haptic feedback (or recoil) that creates a strong vibration to the inertial tracker 508 tracker. The shock mount 500 of disclosed embodiments connects the inertial tracker 508 to the handle 526 while also reducing the shock from simulated recoil which could possibly ruin the tracking data of the inertial tracker 508. In embodiments, a small pressure-sensitive
25 button is placed behind the trigger to send the trigger activation information through electronic circuitry that connects to an interface of the inertial tracker. The inertial tracker may then use a wireless interface such as Bluetooth™ to send the trigger activation signal to the computer for further processing.

[0050] FIGs. 5B and 5C illustrate more examples of a shock mount in use.

30 [0051] FIG. 6 illustrates a weapon simulator 600 in accordance with embodiments of the present invention. Weapon simulator 600 is in the form factor of an automatic rifle. A motor 602 embedded in the grip is configured to generate haptic feedback upon activation of the trigger

604. A battery 612 in the stock of the weapon simulator 600 provides power for the motor 602. Additionally, a wireless transmitter 606 is configured and disposed to provide discharge information to the scenario management system. The wireless transmitter 606 may communicate with a wireless receiver 608 attached to a computer 610. In
5 embodiments, computer 610 is part of the scenario management system. Thus, embodiments include a communication module configured and disposed to wirelessly transmit a trigger indication to the scenario management system in response to activation of the trigger.

[0052] FIG. 7 illustrates a weapon simulator 700 in accordance with additional embodiments of the present invention. Weapon simulator may be in the form factor of a pistol. An optical tracker 702 may be installed on the weapon simulator 700. One or more light sources, indicated as 704 and 706 may be tracked by the motion tracking system to provide information on the position and/or orientation of the weapon simulator to the scenario management system.

[0053] In embodiments, the tracker 702 orients one or more LEDs in specific locations for optimal tracking. A pressure sensitive button is placed behind the handgun trigger and that passes a signal to a computer via a wireless communication protocol such as Bluetooth™, WiFi, Zigbee, or other suitable protocol upon activation of the trigger 708 of the weapon simulator. In embodiments, the unit is self-contained with its own LIPO battery, voltage converter, charger port, and on/off button.

[0054] FIG. 8A – 8F illustrate examples of inverse kinematic solver computations. In embodiments, a full body IK solver allows animation of a human body model in real time based on animations of 5 control points. In embodiments, a body skeleton is divided into the following five bone chains. A spine chain starts with a pelvis bone and ends with a head bone. A left leg chain starts with a pelvis bone and ends with a left foot bone. A right leg chain starts with a pelvis bone and ends with a right foot bone. A left arm chain starts with a left shoulder bone and ends with a left palm bone. A right arm chain starts with a right shoulder bone and ends with a right palm bone. Each chain of bones is solved using a Backward/Forward IK solver gets as an input, two 3D matrices and calculates transform of bones in a chain in 3D space. Changing locations or rotations of either start or end input will change transformation of the bones in the chain. Each chain can consist of any number of bones. Referring now to FIG. 8A, a bone chain 800 is shown in an extended bone state.

Three bones (802, 803, and 804) are extended fully such that endpoint 801 and endpoint 805 are at a maximum possible distance.

[0055] Referring now to FIG. 8B, 8C, and 8D, there are shown examples of non-extended bone states. Referring to FIG. 8B, bone chain 810 is oriented such that the distance D between first endpoint (start) 811 and second endpoint (end) 812 is less than the sum of the lengths of all bones in the bone chain. A similar case exists for bone chain 814 of FIG. 8C and bone chain 815 of FIG. 8D.

[0056] Referring now to FIG. 8E there is a bone chain with a force vector UP applied to it. In order to bend the chain in the known direction, the UP direction has to be defined for the chain. UP direction is a 3D vector. UP direction gets applied to the initial pose and changes it. In the diagram, the UP direction is to the left, which means the chain 819 will bend to the right.

[0057] Referring now to FIG. 8F, forward solving computations are shown. Starting from the current state of the chain, positions of each bone in the chain are found using the forward solving equation:

$$A' = \text{End}' - (\text{End}' - A)$$

[0058] Starting from the bone closest to the end, this equation is repeated for each bone by replacing

End' vector with the location of previous bone in the chain.

For finding B' for example, the following equation is used:

$$B' = A' - (A' - B)$$

Similarly, for C':

$$C' = B' - (B' - C)$$

[0059] Referring now to FIG. 8G, a chain rigidity factor is applied. In embodiments, each bone has a rigidity factor which determines how easily a given bone will change its position when start or end transforms change. A value from 0 to 1 determines where the bone will be

placed between the initial pose and the current pose. In this example, bone 821 has a rigidity factor of 0.5 and so it is moved to halfway between points B and B'.

[0060] Referring now to FIG. 8H, backward solving is performed. Starting from the current state of the chain, positions of each bone in the chain are found using a backward solving equation.
 5 The process starts from the bone closest to the start input, and the equations below are applied:

$$C'' = C$$

10
$$B'' = C'' + (B' - C'')$$

$$A'' = B'' + (A' - B'')$$

[0061] Referring now to FIG. 8i, the orientation of the bones is calculated. Bone chain 823 shows
 15 an initial position, and bone chain 825 shows a final position. In embodiments, orientation of the bones gets calculated after positions are solved for, and it is known where each bone is located and where this bone was in the initial pose. In embodiments, in the initial pose a rotational matrix is constructed for each bone. In the solved pose there is constructed a new rotational matrix for each bone using the same axis order. One axis is parallel to the length
 20 of the bone (Z in the diagram). A second axis is linearly interpolated between the upnode (UP) chain vector multiplied by start and upnode chain vector multiplied by end transform (Y in the diagram). Linear interpolation of this axis allows simulation of twisting of bones along their long axis (z) if end or start transform is twisted. This approach allows adjusting of the extent of the twist for each bone easily by changing one numeric value. Once there
 25 are derived two rotational matrices for the bone, then the offset between them is calculated and this transform offset is applied to the bone. This approach allows rotation of bones independently of their initial orientation. Orientation of bones can be inconsistent in the initial chain pose.

[0062] FIG. 9A is a front view of a wearable sensor 900 in accordance with embodiments of the
 30 present invention. Wearable sensor 900 includes light emitting diode 902 installed therein. A battery within the sensor (not shown) applied power to the light emitting diode 902. In embodiments, the light emitting diode (LED) 902 emits infrared light and does not emit

substantial visible light. This allows the LED 902 of sensor 900 to be detected by the motion tracking system, and yet not be noticeable to the users.

[0063] FIG. 9B is a rear view of the wearable sensor 900 of FIG. 9A. In this view, the adjustable strap 904 can be seen. This strap 904 is used to secure the wearable sensor around a limb (arm, leg) of a user. In embodiments, the strap 904 may have a fastener such as a snap, hook and loop fastener, or other suitable fastening mechanism. Wearable sensor 900 may be similar to sensors 206 shown in FIG. 1.

[0064] FIG. 10 is a flowchart 1000 indicating process steps for embodiments of the present invention. At process step 1002, a user position is determined. The user may be wearing one or more wearable devices such as position sensors and/or position indicators. The wearable devices may emit infrared light that is tracked by a motion tracking system. In process step 1004, an initial physiological orientation is determined. In some embodiments, a wearable device is worn on each limb, allowing the motion tracking system to determine physiological orientation. The physiological orientation can include a stance (e.g. standing, crouching, prone), and may further including a direction the user is facing. In process step 1006, a simulated firearm discharge is detected. In embodiments, this can include a weapon simulator in the form factor of a firearm. The weapon simulator includes a power source (battery) and a wireless transmitter that is configured and disposed to transmit a trigger activation indication to a computer to indicate that the weapon simulator has discharged (e.g. a user pulled the trigger on the weapon simulator). The weapon simulator may or may not actually shoot a projectile. In process step 1008, a user reaction is determined. This can include determining a second physiological orientation of the user at some predetermined time after the detection of the simulated firearm discharge. The second physiological orientation can include a position of a person, position of the limbs of that person, orientation of the torso of the person (which way the torso is facing), and/or orientation of the head of the person (which way the head of the user is facing). Thus, in embodiments, determining a physiological orientation of the user comprises determining a facial direction of the user.

[0065] Additionally, in embodiments with a user-facing camera (e.g. included in virtual or augmented reality goggles), an eye gaze direction may further be included in the physiological orientation. Various attributes can then be evaluated, including, but not limited to, the time required for the user to achieve the second physiological orientation (e.g.

a measure of how long did it take the user to get into a crouch position in response to hearing and/or seeing a simulated firearm discharge), the correctness of the second physiological orientation as compared to a known orientation (e.g. a measure of if the user's crouch is sufficiently low), and/or the time required to draw a weapon (e.g. a measure of the time required for the user to pull a weapon simulator from a holster and orient it in a position to fire). Other attributes of user reaction may be evaluated instead of, or in addition to the aforementioned attributes in embodiments of the present invention.

[0066] FIG. 11 is a flowchart 1100 indicating additional process steps for embodiments of the present invention. In process step 1102, a final position time is determined. This may include determining a time where the user's level of motion is below a predetermined threshold. Thus, embodiments include further comprising measuring a duration from a time of the simulated firearm discharge to a time of detecting the determined physiological orientation. As an example, when a user is in the process of quickly moving from a standing position to a crouched position, there is a relatively large amount of motion. Once the user is stabilized in the crouched position, there is relatively less motion. The time when the user is substantially still may be recorded as a final position time. At process step 1104, a final position quality is determined. This may include utilization of motion tracking data to determine how close the user's physiological orientation is to an expected physiological orientation. This can include an assessment of if the user is in a proper stance/position, facing the proper direction, appropriately drawing his weapon simulator, and/or other factors. In process step 1106, the final position time is compared to average times. In process step 1108, a score is generated based on the comparison to the average time. In some embodiments, the score may be generated using the formula:

$$K(1 - X)$$

Where:

K is a constant;

X is the final position time in seconds.

[0067] As an example, if an average time for a law enforcement professional to go from standing to crouched is 400 milliseconds, then the final position time may be compared against the

average time using the above formula. If K is 116, then the following score is achieved for different crouch times:

Crouch time (milliseconds)	Score
400	69.6
500	50
600	46.4
200	92.8
300	81.2

5 [0068] As can be seen from the table above, the formula returns a score such that a user with an average time of 400 milliseconds earns a score of about 70, while a user with a score of 300 returns a higher score (81.2). Similarly, a user with a relatively slow time of 600 milliseconds returns a low score of 46.4. This concept can also be applied to other attributes, such as position quality, weapon draw time, weapon discharge time, and/or other
 10 attributes. In embodiments, the score for each attribute may be combined into an overall score.

[0069] FIG. 12 is an exemplary user interface 1200 in accordance with embodiments of the present invention. User interface 1200 may be implemented on a client device such as client device 116 of FIG. 1. The user interface may be used to allow users and/or trainers and coaches to review performance. User interface 1200 includes a video window 1202 that may show
 15 video and/or a virtual animated rendition of the user performance. In some embodiments, real video and animated graphics may be composited together in video window 1202. User interface 1200 further includes a name field 1204, a scenario name 1206, a final position score 1208, a reaction time 1210, a weapon draw time 1214, and a weapon discharge time
 20 1216. In embodiments, the weapon draw time 1216 may be the time required by the user to move his weapon simulator from a holstered position to a ready position as determined by the motion tracking system. In embodiments, the weapon discharge time may be the time required by the user to fire the weapon simulator after getting the weapon simulator into the ready position (e.g. aimed at a target). The data analysis component (412 of FIG. 3) may
 25 further provide computer-generated recommendations, which may be rendered in field 1218. The recommendations can be based on scores and/or times for one or more attributes during

a scenario execution. The user interface 1200 is merely exemplary, and other user interfaces are possible showing more, fewer, or different fields in some embodiments.

[0070] FIG. 13 shows an additional embodiment. Weapon simulator 1300 includes additional stock 1302 affixed to the rear end of the weapon simulator. This enables users wearing a head-mounted display (HMD) to get into a shooting position without having the HMD bump into the stock end of the weapon simulator, thereby allowing for a more unencumbered user experience.

[0071] Some embodiments may provide an untethered experience with computers mounted in backpacks. Such embodiments may include, but are not limited to, an MSR V1 with a GTX 1070, or an HP ZVR with a GTX 1070. The computers may be configured with an Intel i7 processor and at least 16 GB of RAM. Other backpack computers are possible in embodiments of the present invention.

[0072] As can now be appreciated, disclosed embodiments provide an improved training system for firearm usage. A motion tracking system tracks the motion of one or more users. Users use a weapon simulator that integrates with a scenario management system. The scenario management system thus obtains information about weapon position and weapon discharge, as well as position of the users. The scenario management system can generate scenarios where live participants, virtual participants, and/or computer-generated targets work together or against each other to conduct training drills. Through the use of virtual reality and/or augmented reality, various landscapes, terrain, buildings, and other factors can be simulated. The reactions of users can be timed and assessed, allowing for improved review of the performance of users such as military and law enforcement personnel. In this way, the effectiveness and safety of these people can be continuously monitored and improved.

[0073] FIG. 14 is illustrative of an embodiment of a Full-Body Inverse Kinematics (FBIK) module 1400 which may be used in exemplary training system embodiments. For example, one or more FBIK modules may be represented by or included in wearable sensors 206 in FIG. 1. As shown, an FBIK module 1400 may comprise an enclosure 1410 that contains its other components. In embodiments, enclosure 1410 may be configured to be attached to or coupled to a wearable strap, similar to the sensor shown coupled to an adjustable strap 904 in FIGs. 9A and 9B and described in the corresponding disclosure. In other embodiments, the wearable strap may include a pocket (not shown). The FBIK module enclosure may then

be in the form of a closed box or puck that may be easily inserted into and removed from the pocket.

[0074] In embodiments, the FBIK module 1400 may include a rechargeable battery 1420. To recharge the battery, the enclosure 1410 may have a port 1450 to be coupled to a charger (not shown). In other embodiments, the FBIK module puck 1400 may be configured to be opened and closed in order to replace a non-rechargeable battery (not shown), or a battery may be separate from the puck and electrically coupled to it with a cord (not shown).

[0075] One or more FBIK modules 1400 may be used, for example, in conjunction with a motion tracking system, a motion modeling system, a firearm simulation training system, or the like, which may be or include a system embodiment described previously. The FBIK module may be worn by a training participant to track their extremities during a Virtual Reality (VR) scenario in an immersive simulation environment. Illustratively, the FBIK module 1400 can be used in conjunction with an immersive trainer such as that offered by V-Armed of Brooklyn, NY (<https://www.v-armed.com>). The FBIK module preferably uses active tag tracking technology, such as that offered by Optitrack's active tag technology. In embodiments, each FBIK module may include a plurality of lights 1430, preferably infrared lights that can't be seen by the naked eye. A controller 1435 may be included in the FBIK module, configured to flash the lights in distinct patterns that can be seen by the motion tracking system's cameras and identified. The motion tracking system may be similar to motion tracking system 130 of FIG. 1, for example. The motion tracking system triangulates the markers' positions in 6 degrees of freedom (forward and back, left and right, up and down) to determine the markers' location and relative orientation within the 3D space of the VR training environment. Further, by reading the flashing pattern, the system is able to distinguish the participants wearing FBIK trackers from each other.

[0076] In embodiments, an FBIK module 1400 or one or more active markers 1430 may also contain an Inertial Measurement Unit (IMU) 1440 that uses one or more accelerometers 1415, gyroscopes 1420, magnetometers 1425, or combinations of these. The IMU 1440 may be configured to use information provided by these components to determine a specific force, linear and angular motion, momentum, acceleration, and/or orientation, of a user's extremity on which the FBIK module is worn. The IMU 1440 may also transmit signals providing information, for example using transmitter 1445, that can be received and used by the motion tracking system to keep track of the markers when they are occluded from

system cameras by objects in the training environment. To provide even more complete user position and orientation information, the FBIK module may also be used in conjunction with a backpack tracker, a Head Mounted Display (HMD) tracker, and the like, preferably using a tracking algorithm such as that used by V-Armed's tracking systems.

5 [0077] In embodiments, prior to beginning to track a person, a so-called T-Pose calibration may be performed, preferably quickly (e.g., within a few seconds or less), using calibration information derived from an image of the person standing with arms extended to the sides (i.e., forming a "T"). The T-pose calibration information may be provided to an avatar creator, which may be a program executing in a scenario management system such as that
10 shown as element 102 in FIG. 1. The avatar creator may thereby create a virtual avatar that matches the dimensions and general appearance of the real person. A photograph of the person's face may also be mapped by the avatar creator onto the created avatar's facial area, to make the avatar appear more like the person it represents in the training scenario. During an ongoing scenario, the scenario management system may provide to each participant the
15 created avatars of all the other participants, to be rendered for example disposed in the VR environment being experienced by the participants.

[0078] In embodiments, one or more of the active tags 1430 may contain or be associated with an inertial measurement unit (IMU) 1425, which compensates for the loss of line-of-sight tracking information when one or more markers 1455 are occluded by objects in the training
20 environment. In embodiments, commercially available IMUs 1425 may be used. Illustratively, IMUs developed by Optitrack may be used. Further, such IMUs may be found in commercially available training systems such as V-Armed, which uses this technology in their tracking devices.

[0079] The sensors and wireless communication components may be implemented using a custom
25 printed circuit board (PCB) comprising onboard components.

[0080] FIG. 15A is a perspective view of one embodiment of an FBIK module and base plate, 1500,
which may be represented by or included in wearable sensors 206 in FIG. 1. The FBIK module enclosure is shown in the form of a closed box or puck 1510. In embodiments, the base plate may be attached to an adjustable arm band. Some embodiments may comprise a
30 pocket attached to the armband (not shown). The puck 1510 may then be inserted onto the pocket and secured, such as by a button, zipper, hook and loop fastener, or the like, to secure the pocket opening directly, or to secure a flap to cover the pocket opening, or the like. The

puck 1510 may be easily inserted into and removed from the pocket. In embodiments, the strap may be configured to be coupled to a base plate 1520, which may have a locking mechanism. As illustrated in FIG. 15A, the locking mechanism comprises a pair of rails 1522 (one shown, the other facing it on the opposite wall of the base plate 1520 and not visible in the perspective view shown) and a clip 1524. The puck 1510 can then be configured with a corresponding locking mechanism, illustrated by showing one of a pair of slots 1526 into which the rails slide (the other slot is on the opposite side of the puck and not visible in the perspective view shown). The puck 1510 and the base plate 1520 are shown assembled as 1530, arranged such that the puck is slid into the base plate and locked into position by the clip 1524.

[0081] FIG. 15B is another exemplary embodiment of a wearable sensor, similar to that shown in FIG. 15A. In the figure, adjustable strap 1534 is fitted to the wearer using buckles 1536. One or more sensors may be contained in tracker module 1530, which is coupled to the strap 1534 by sliding slots on the tracking module onto the rails of a base plate affixed to the strap, as shown in FIG. 15A. A coupling mechanism releases the enclosure by pressing release tab 1538. The tracker module can then be slid off the base plate, and replaced with another tracker module that may comprise the same or different components. The illustrated embodiment includes tracker elements 1542, which may be active or passive. The tracker module 1530 may comprise one or more sensors, transceivers, processors, rechargeable or replaceable batteries, and the like.

[0082] In embodiments, a novel self-calibrating method may be used. In the method, each physical tracker may be assigned to a virtual extremity body part, and must maintain a 3 dimensional offset from the virtual body part as it does from the corresponding tracked real body part of a user. In addition, the virtual body height and arm length may closely match the proportions of the user's physical body. In embodiments, this process occurs automatically during the VR experience, even without running any calibration step in which people are required to perform specific activities for such calibration. The automatic calibration is based on a continuous sampling of poses and movement trajectories of particular trackers. Each pose allows the occurrence of a calibration of tracker position(s), or a refinement to an existing calibration of trackers.

[0083] FIG. 16 shows the steps of an exemplary method 1600 for performing such calibration and refinement. As shown, an initial calibration is performed for a person participating in a

simulation, such as a police officer firearm usage training simulation. This includes setting a virtual character height to the height of a tracker worn by a person on or about their head, such as in a helmet or on a headband 1610. Additional trackers are worn on the extremities. The body part being tracked by each tracker worn on an extremity is identified by a motion tracking system, such as that described previously, based on the tracker's 3D location in space, flashing LED patterns, or the like, 1615. For example, trackers being worn on right and left wrists and ankles are identified as such. During an initial calibration phase, an offset is determined that estimates the distance from where each tracker is actually located, to the position in space that best matches the body part being tracked by it, 1620. For example, a tracker worn on a person's wrist or ankle may be offset by an amount indicative of the distance between the actual location of the tracker, and the location of the person's anatomy that represents the point on or in the body that would ideally have been directly tracked, such as the center of the person's hand or foot.

[0084] As the person moves, the position and orientation of each body part is refined based on the trajectory of the corresponding tracker as it travels in space when the person moves, 1625. Further adjustments may be made to the position and orientation of virtual body parts based on the fine-tuned movements of the corresponding trackers that control them. Each tracker may be solved independently of the others so that the movement of one body part doesn't affect how any other is tracked or rendered. For each detected movement of a tracker on a tracked body part, the speed and direction of movement of the tracker is determined. Information of the physical characteristics and limitations of the tracked body part may also be accounted for. For example, when a tracked wrist moves in an arc, a pivot point (center) of the arc may be determined based on the wrist movement trajectory. The arc center represents a shoulder joint in the person's physical body. Based on this, together with the offset position of the wrist tracker, the length of the physical arm can be determined or adjusted. The virtual arm may be then be rendered based on the adjustments to the movement, orientation, and length of each monitored physical body part. The offset of trackers worn on a person's ankles to track their feet may similarly be adjusted based on the movement of the person's legs. In addition, if the person is moving forward, their feet are expected to face forward as well. So, based on the tracked movement, the position of the ankle trackers may be refined, and the virtual feet controlled by them may be adjusted and made to face forward in the direction of the movement.

[0085] In embodiments, at least 6 active sensors may be used to make adjustments to the virtual person corresponding to the person whose body parts are tracked. Further, the position of any part of the person's physical body not tracked by an active sensor may be estimated as needed from data already obtained.

5 [0086] Data used in the foregoing method may be further enhanced to include the effects of changes in the heart rate and/or other biometrics of the person being tracked, if any. In embodiments, biometric data may be obtained from appropriate sensors (e.g., a heart rate monitor) worn by the tracked person.

10 [0087] Detected tracker movements may initiate making such refinements. In embodiments, step 1625 may be initiated only when the detected movement is greater than a predetermined threshold. For example, a very small movement of an extremity may be ignored because the movement of the corresponding body part would also be very small. In other embodiments, step 1625 may be repeated whenever a tracker movement is detected, 1630. Each iteration of step 1625 may be completed for each tracker to make calibration adjustments to its
15 corresponding body part. A calculated adjustment may be disregarded if it is deemed to be insignificant. For example, a calculated adjustment to a body part may be ignored if it is smaller than a predetermined distance. The predetermined distance may be different for each tracked body part or set of body parts (e.g., hands versus feet).

20 [0088] The method of making adjustments is completed when the person's participation in the simulation is concluded, 1635.

25 [0089] At least part of the present invention may be embodied in a system, a method, and/or a computer program product at any possible technical detail level of integration. The computer program product may include a non-transitory computer readable storage medium or media, having computer readable program instructions stored therein for causing a processor to carry out aspects of the present invention.

30 [0090] Each of the above methods may be executed on one or more processors on one or more computer systems. Embodiments may include various forms of distributed computing, client/server computing, and cloud based computing. Further, it will be understood that the depicted steps or boxes contained in the disclosed flowcharts are solely illustrative and explanatory. The steps may be modified, omitted, repeated, or re-ordered without departing from the scope of this disclosure. Further, each step may contain one or more sub-steps. While the foregoing drawings and description set forth functional aspects of the disclosed

systems, no particular implementation or arrangement of software and/or hardware should be inferred from these descriptions unless explicitly stated or otherwise clear from the context. All such arrangements of software and/or hardware are intended to fall within the scope of this disclosure.

5 [0091] The block diagrams and flowchart illustrations depict methods, apparatus, systems, and computer program products. Any and all such functions, generally referred to herein as a “circuit,” “module,” or “system” may be implemented by computer program instructions, by special-purpose hardware-based computer systems, by combinations of special purpose hardware and computer instructions, by combinations of general purpose hardware and computer instructions, and so on.

10 [0092] It will be understood that a computer may include a computer program product from a computer-readable storage medium and that this medium may be internal or external, removable and replaceable, or fixed. In addition, a computer may include a Basic Input/Output System (BIOS), firmware, an operating system, a database, or the like that may include, interface with, or support the software and hardware described herein.

15 [0093] Embodiments of the present invention are neither limited to conventional computer applications nor the programmable apparatus that run them. To illustrate: the embodiments of the presently claimed invention could include an optical computer, quantum computer, analog computer, or the like. A computer program may be loaded onto a computer to produce a particular machine that may perform any and all of the depicted functions. This particular machine provides a means for carrying out any and all of the depicted functions.

20 [0094] Any combination of one or more computer readable media may be utilized including but not limited to: a non-transitory computer readable medium for storage; an electronic, magnetic, optical, electromagnetic, infrared, or semiconductor computer readable storage medium or any suitable combination of the foregoing; a portable computer diskette; a hard disk; a random access memory (RAM); a read-only memory (ROM), an erasable programmable read-only memory (EPROM, Flash, MRAM, FeRAM, or phase change memory); an optical fiber; a portable compact disc; an optical storage device; a magnetic storage device; or any suitable combination of the foregoing. In the context of this document, a computer readable storage medium may be any tangible medium that can contain or store a program for use by
25
30 or in connection with an instruction execution system, apparatus, or device.

[0095] Computer readable program instructions described herein can be downloaded to respective computing/processing devices from a computer readable storage medium or to an external computer or external storage device via a network, for example, the Internet, a local area network, a wide area network and/or a wireless network. The network may comprise copper
5 transmission cables, optical transmission fibers, wireless transmission, routers, firewalls, switches, gateway computers and/or edge servers. A network adapter card or network interface in each computing/processing device receives computer readable program instructions from the network and forwards the computer readable program instructions for storage in a computer readable storage medium within the respective computing/processing
10 device. Program data may also be received via the network adapter or network interface.

[0096] These computer readable program instructions may be provided to a processor of a computer, or other programmable data processing apparatus to produce a machine, such that the instructions, which execute via the processor of the computer or other programmable
15 data processing apparatus, create means for implementing the functions/acts specified in the flowchart and/or block diagram block or blocks. These computer readable program instructions may also be stored in a computer readable storage medium that can direct a computer, a programmable data processing apparatus, and/or other devices to function in a particular manner, such that the computer readable storage medium having instructions
20 stored therein comprises an article of manufacture including instructions which implement aspects of the function/act specified in the flowchart and/or block diagram block or blocks.

[0097] It will be appreciated that computer program instructions may include computer executable code. A variety of languages for expressing computer program instructions may include
25 without limitation C, C++, Java, JavaScript™, assembly language, Perl, Python, Ruby, hardware description languages, database programming languages, functional programming languages, imperative programming languages, and so on. In embodiments, computer program instructions may be stored, compiled, or interpreted to run on a computer, a programmable data processing apparatus, a heterogeneous combination of processors or
30 processor architectures, and so on. Without limitation, embodiments of the present invention may take the form of web-based computer software, which includes client/server software, software-as-a-service, peer-to-peer software, or the like.

[0098] In embodiments, a computer may enable execution of computer program instructions including multiple programs or threads. The multiple programs or threads may be processed

approximately simultaneously to enhance utilization of the processor and to facilitate substantially simultaneous functions. By way of implementation, any and all methods, program codes, program instructions, and the like described herein may be implemented in one or more threads which may in turn spawn other threads, which may themselves have priorities associated with them. In some embodiments, a computer may process these threads based on priority or other order.

[0099] Unless explicitly stated or otherwise clear from the context, the verbs “execute” and “process” may be used interchangeably to indicate execute, process, interpret, compile, assemble, link, load, or a combination of the foregoing. Therefore, embodiments that execute or process computer program instructions, computer-executable code, or the like may act upon the instructions or code in any and all of the ways described. Furthermore, the method steps shown are intended to include any suitable method of causing one or more parties or entities to perform the steps.

[0100] The terminology used herein is for describing particular aspects only and is not intended to be limiting of the invention. As used herein, the singular forms “a”, “an” and “the” are intended to include the plural forms as well, unless the context clearly indicates otherwise. It will be further understood that the terms “include” and “including” when used in this specification, specify the presence of stated features, integers, steps, operations, elements, and/or components, but do not preclude the presence or addition of one or more other features, integers, steps, operations, elements, components, and/or groups thereof. Certain examples and elements described in the present specification, including in the claims and as illustrated in the figures, may be distinguished or otherwise identified from others by unique adjectives (e.g. a “first” element distinguished from another “second” or “third” of a plurality of elements, a “primary” distinguished from a “secondary” one or “another” item, etc.) Such identifying adjectives are generally used to reduce confusion or uncertainty, and are not to be construed to limit the claims to any specific illustrated element or embodiment, or to imply any precedence, ordering or ranking of any claim elements, limitations or process steps.

[0101] While the invention has been disclosed in connection with preferred embodiments shown and described in detail, various modifications and improvements thereon will become apparent to those skilled in the art. Accordingly, the foregoing examples should not limit the

spirit and scope of the present invention; rather it should be understood in the broadest sense allowable by law.

What is claimed is:

1. A Full-Body Inverse Kinematic (FBIK) module for use in tracking a user in a virtual reality (VR) environment, the FBIK module comprising:

5 an enclosure containing:

a power source;

a plurality of active tags, each tag having a light for use by a motion tracking system to track the user of the FBIK module; and

10 a controller that flashes the lights in distinct patterns identifiable by the motion tracking system for use by the motion tracking system to identify the user of the FBIK module.

2. The FBIK module of claim 1, wherein the enclosure is configured to be coupled to a wearable adjustable strap fitted to the user.

15 3. The FBIK module of claim 2, wherein the strap includes a pocket configured to receive the FBIK module.

4. The FBIK module of claim 4, wherein the enclosure is a rigid puck that protects its contents and is configured to be removably inserted into the pocket.

20

5. The FBIK module of claim 4, wherein the pocket contains a base plate, and the base plate and the puck are configured with a locking mechanism that secures the puck to the base plate in the pocket.

25 6. The FBIK module of claim 1, wherein the active tag lights radiate at a frequency not visible by the human eye, but visible to a least one camera of the motion tracking system.

7. The FBIK module of claim 6, further comprising a light controller configured to flash the lights in distinct patterns that can be identified by the motion tracking system.

30

8. The FBIK module of claim 7, wherein the motion tracking system triangulates the active markers' positions in 6 degrees of freedom to determine the markers' location and relative orientation within a 3D space of the VR environment.

5 9. The FBIK module of claim 8, wherein:

the FBIK module is one of a plurality of substantially similar FBIK modules worn on the extremities of a user, and

the motion tracking system triangulates the positions of all of the active markers of the FBIK modules worn by the user and determines from the tags' positions at least one of a movement, an orientation, and a posture of the user.

10. The FBIK module of claim 1, wherein the power source is a battery.

11. The FBIK module of claim 10, further comprising a charging port, wherein the enclosed battery is coupled to a charging source via the charging port.

12. The FBIK module of claim 10, further comprising a battery port, wherein the battery is external to the enclosure and is coupled to the enclosure via the battery port.

20 13. The FBIK module of claim 1, further comprising an inertial measurement unit (IMU) that compensates for loss of visibility of the markers when they are occluded by an object between the FBIK module and a camera of the tracking system.

25 14. The FBIK module of claim 13, wherein the IMU uses information obtained from at least one of an accelerometer, a gyroscope, and a magnetometer, included in the FBIK module, to determine extremity information including at least one of a force, a linear motion, an angular motion, a momentum, an acceleration, and an orientation, of a user's extremity on which the FBIK module is worn.

30 15. The FBIK module of claim 14 further comprising a transmitter to wirelessly transmit at least a portion of the extremity information to the motion tracking system for keeping track of the markers when they are occluded from a system camera by an object in the VR environment.

16. The FBIK module of claim 1, wherein the motion tracking system combines information obtained from the FBIK module with information obtained from at least one of a backpack tracker and a head mounted display tracker to more accurately track the user.

5

17. The FBIK module of claim 1, wherein T-Pose calibration information of the user is used by a scenario management system to render an avatar of the user for display to other users in the VR environment.

10 18. A method for tracking body parts of a person wearing active trackers, comprising:
setting a height of a virtual character equal to a height of a head tracker on a person participating in a training simulation;

identifying a body part being tracked by each of a plurality of trackers worn by the person, based on the tracker's location;

15 determining an offset for each tracker, between its actual location and a corresponding ideal location on the person's anatomy, using predetermined information of the corresponding identified body part; and

20 in the case a modification is more than a threshold value, modifying information of at least one of a position and an orientation of at least one identified body part using information of a movement of its corresponding tracker.

19. The method of claim 18, further comprising:

25 creating and modifying, by a scenario management system, an avatar of the person wearing the trackers, using information of the trackers' location, the offsets to the ideal location, and the orientations of the corresponding body parts.

20. The method of claim 19, further comprising:

30 the scenario management system sending information of the created and modified avatar to at least one participant in a training exercise for displaying the created and modified avatar to the participant in real time.

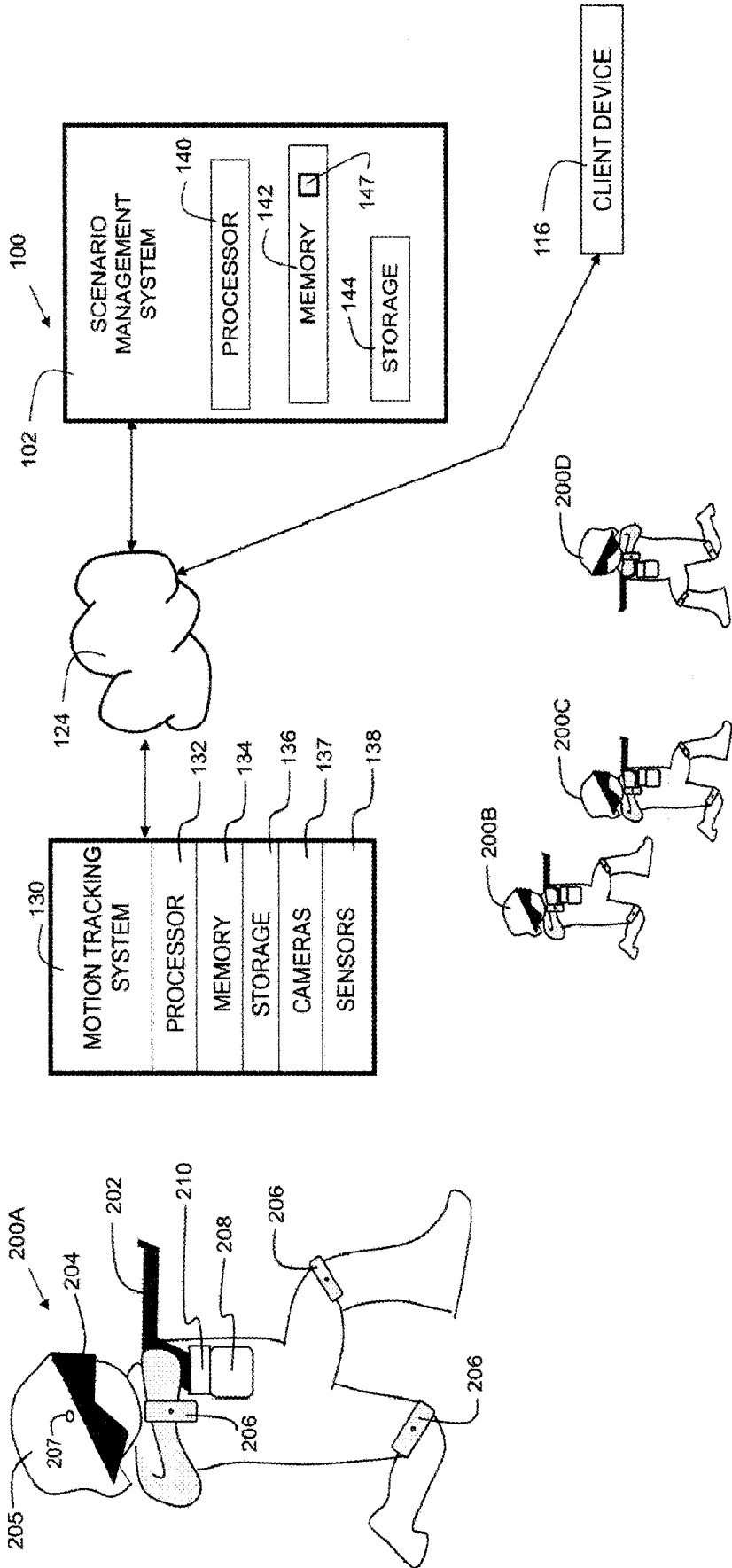

FIG. 1

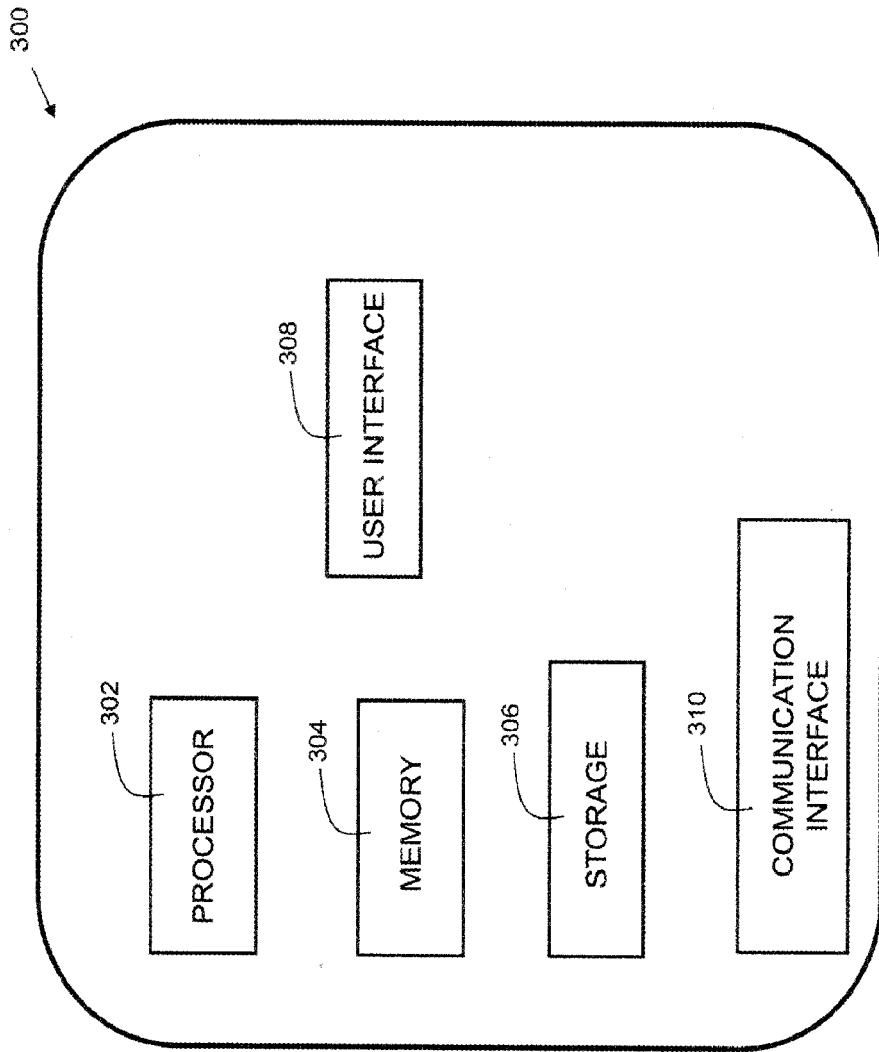

FIG. 2

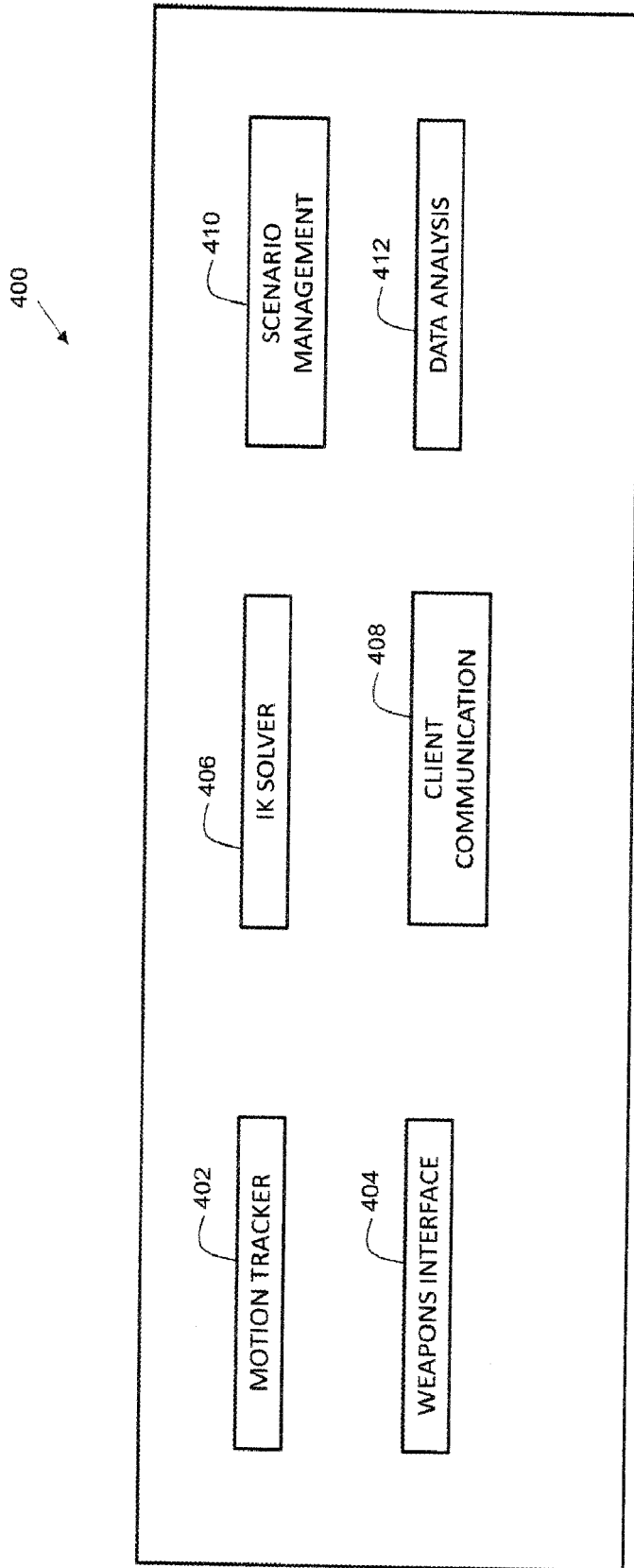

FIG. 3

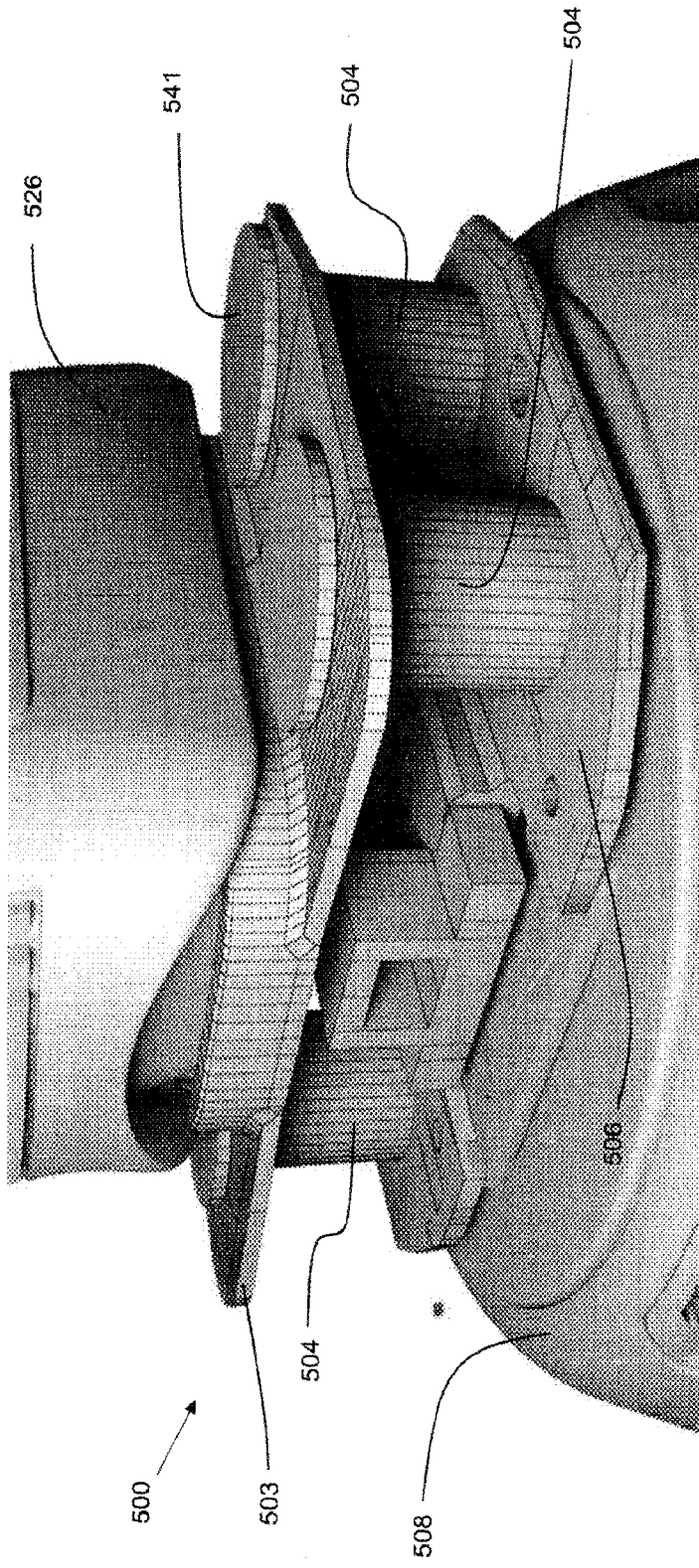

FIG. 4A

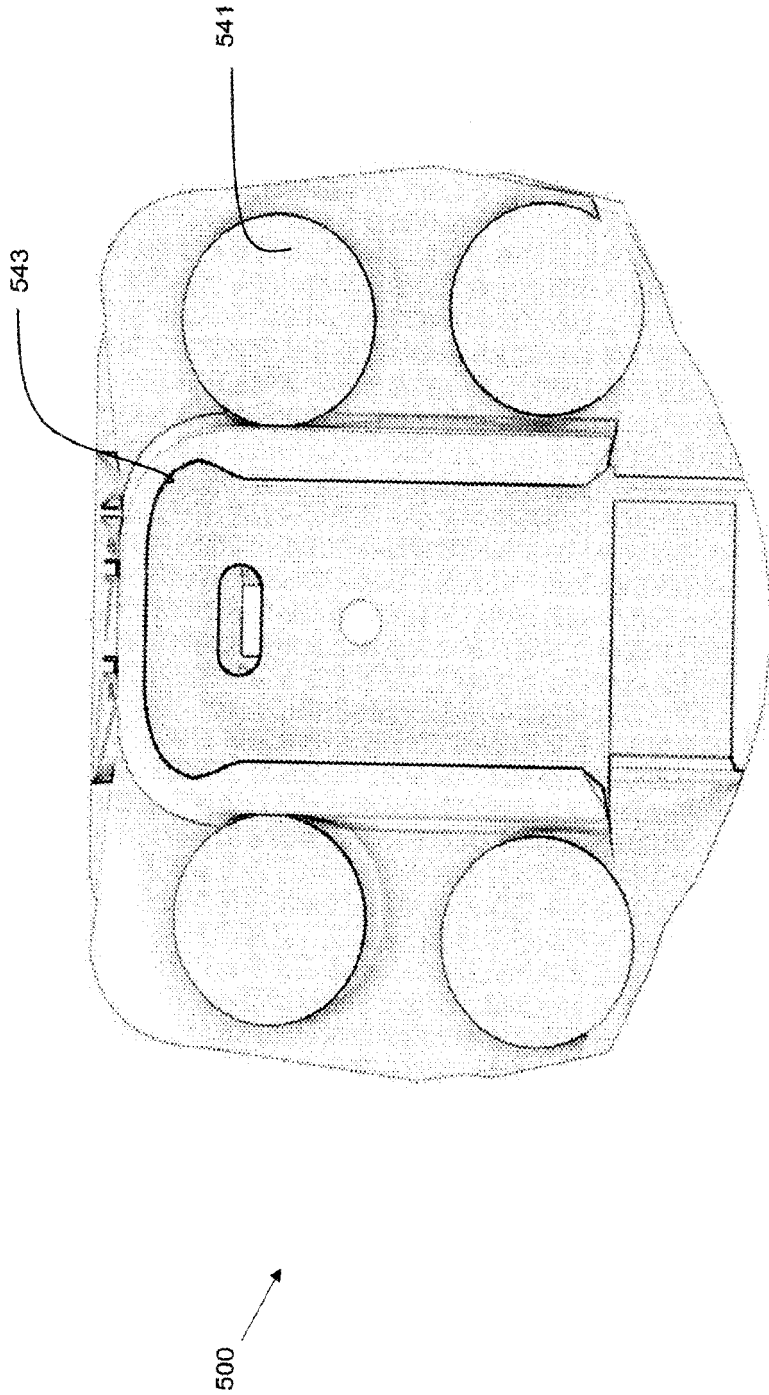

FIG. 4B

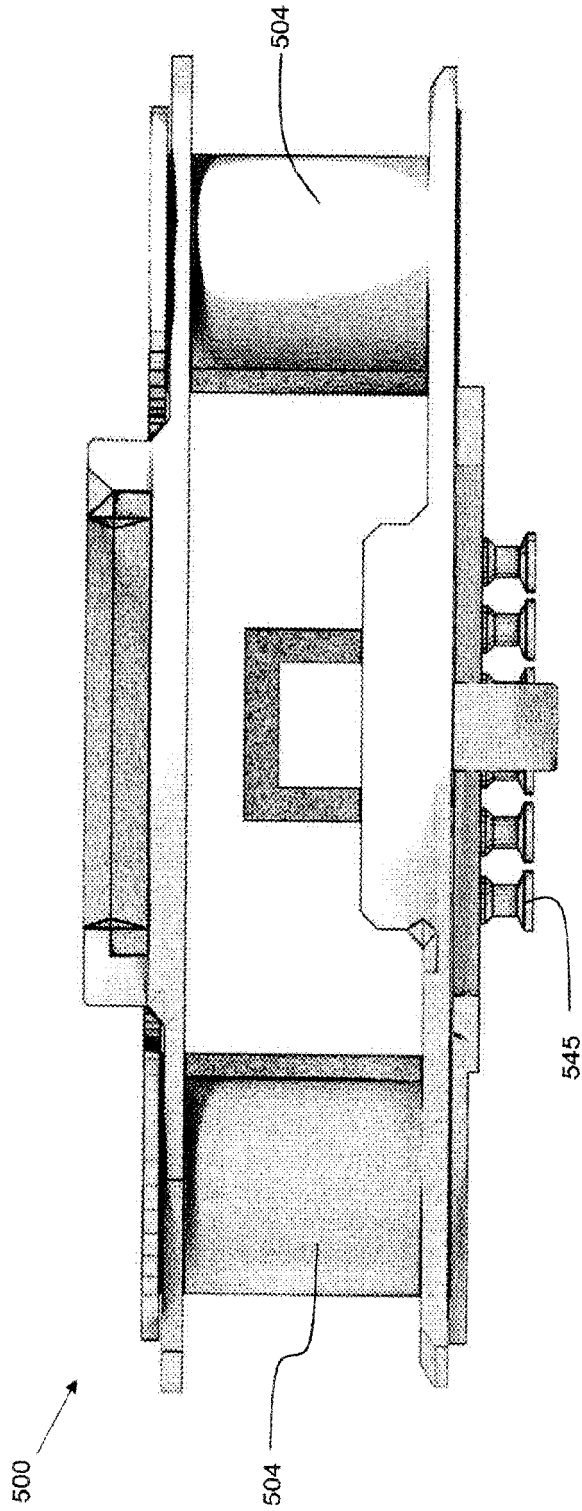

FIG. 4C

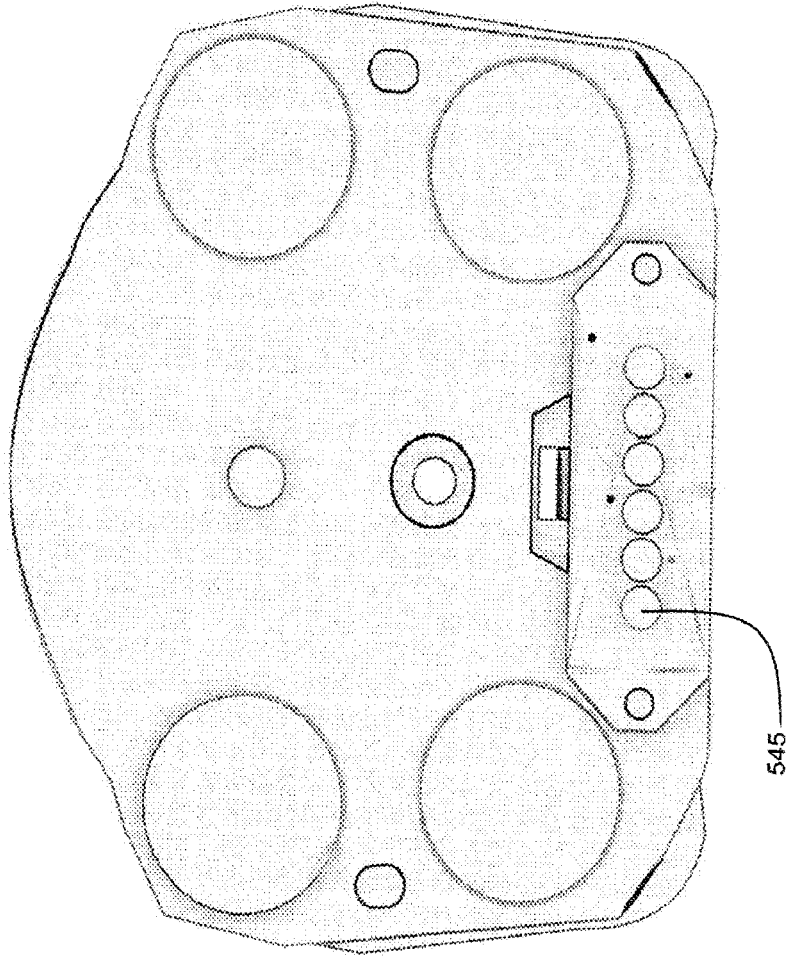

FIG. 4D

500

545

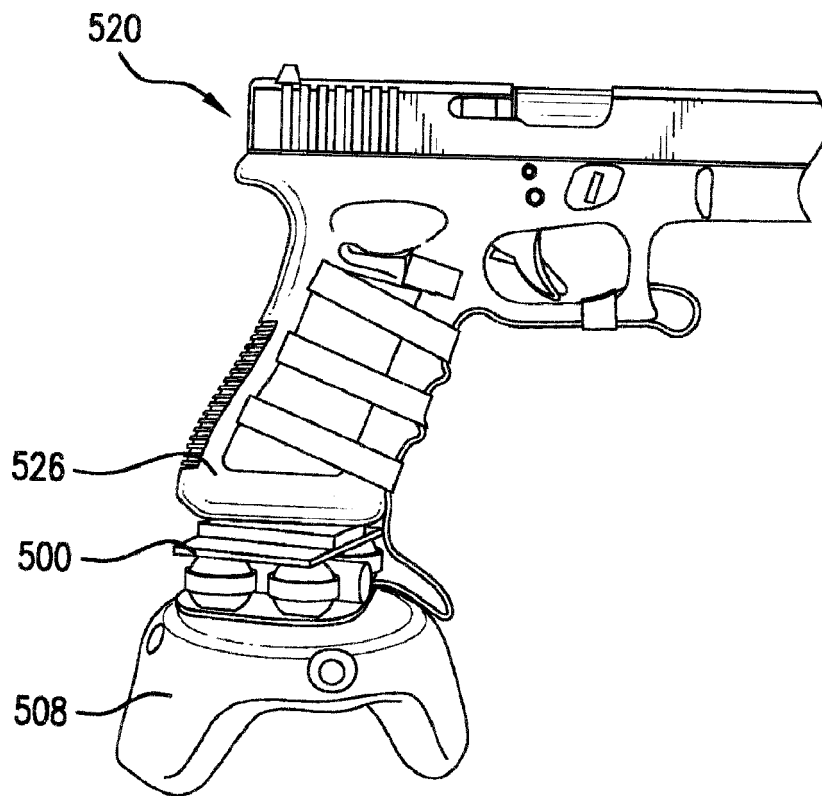

FIG. 5A

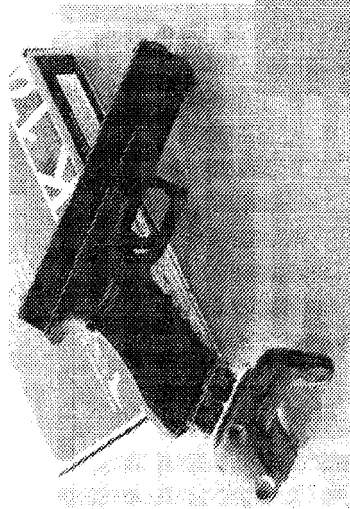

FIG. 5B

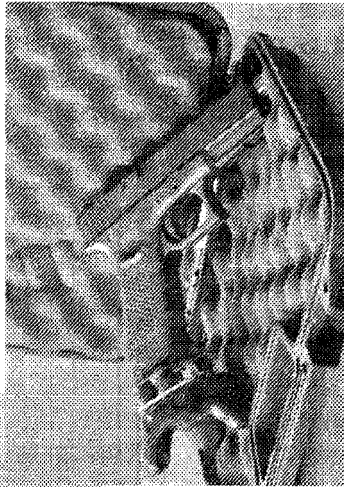

FIG. 5C

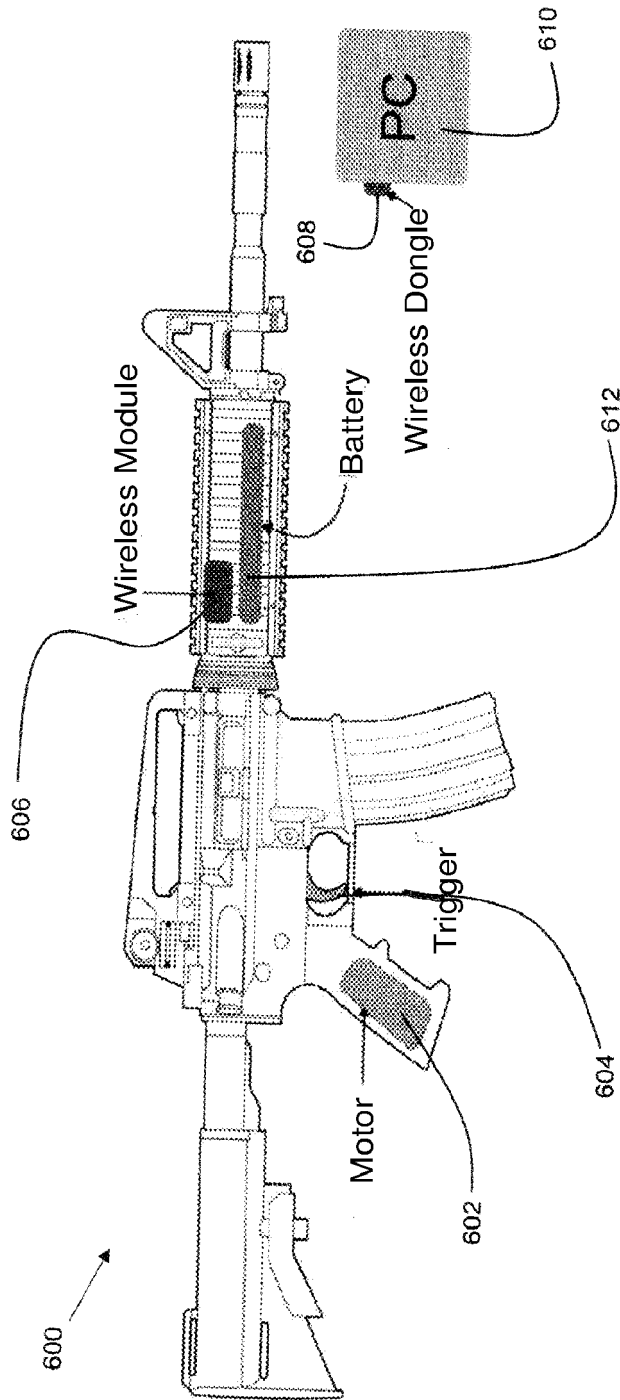

FIG. 6

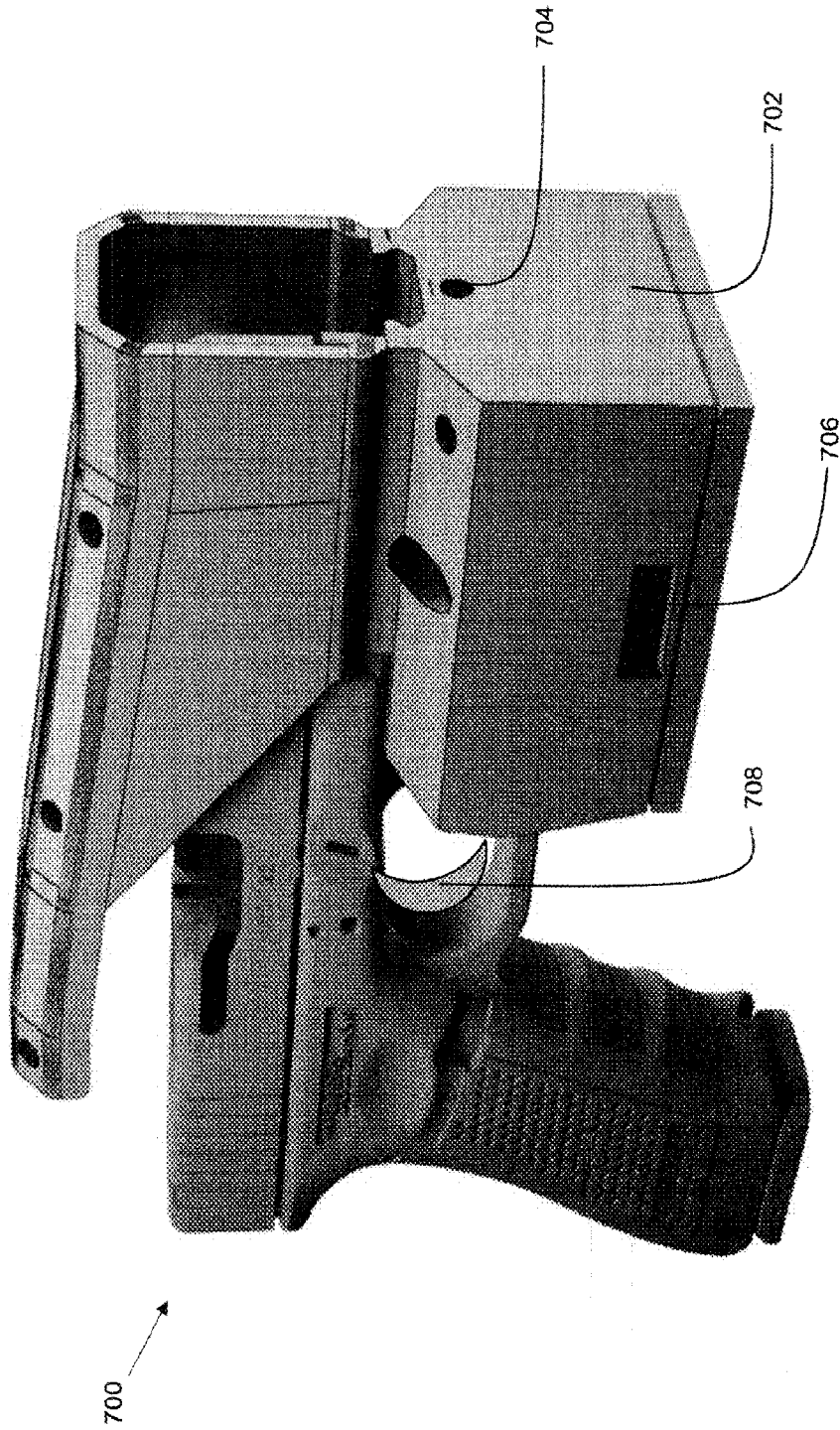

FIG. 7

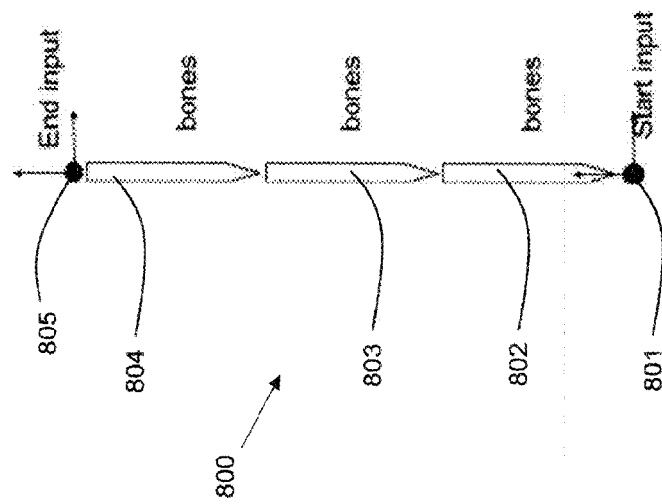
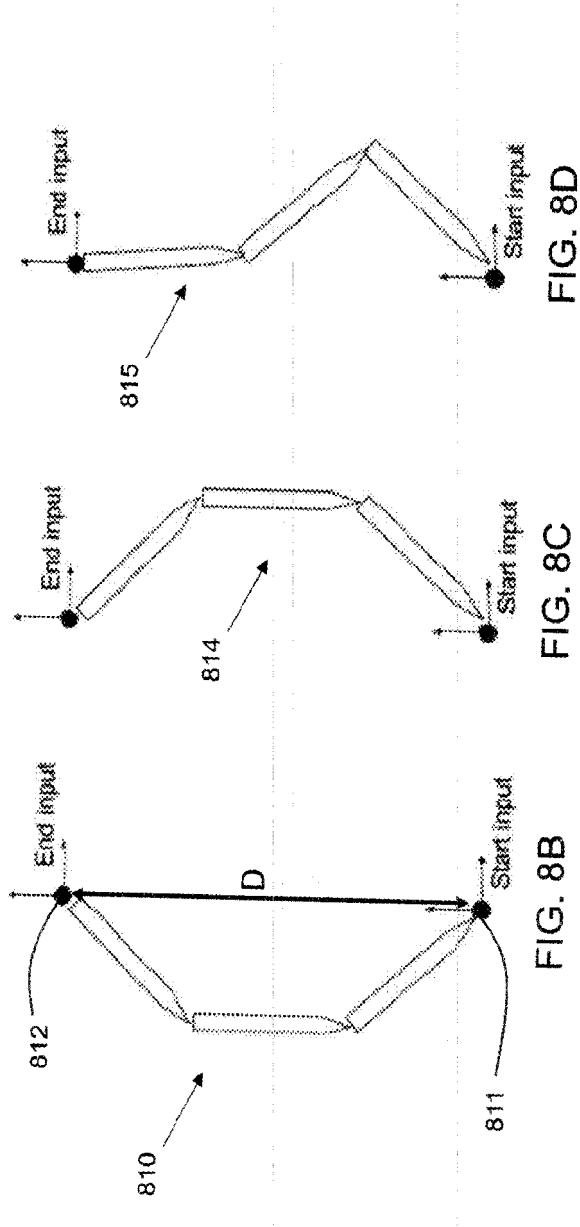

FIG. 8A



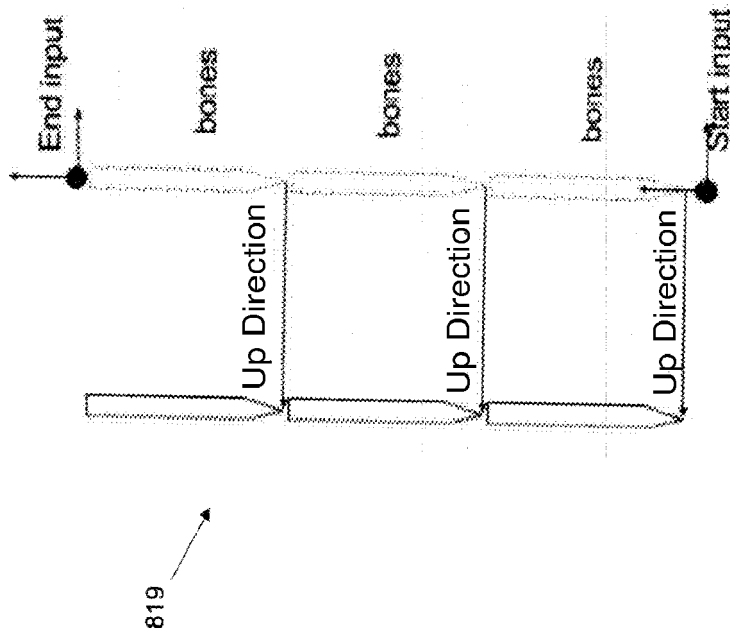

FIG. 8E

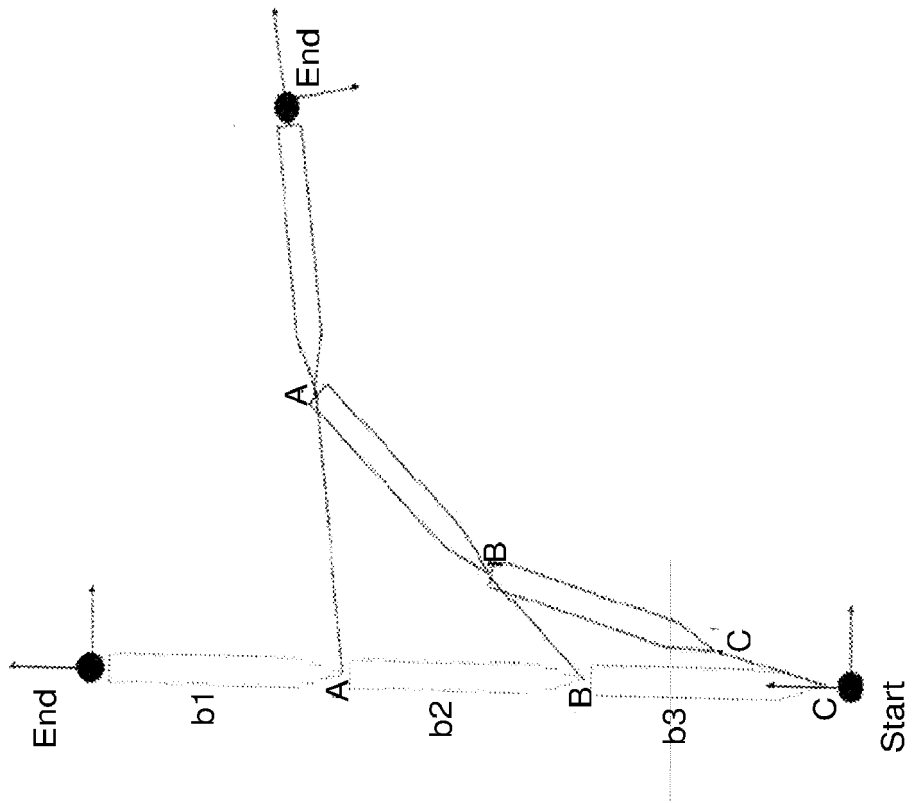

FIG. 8F

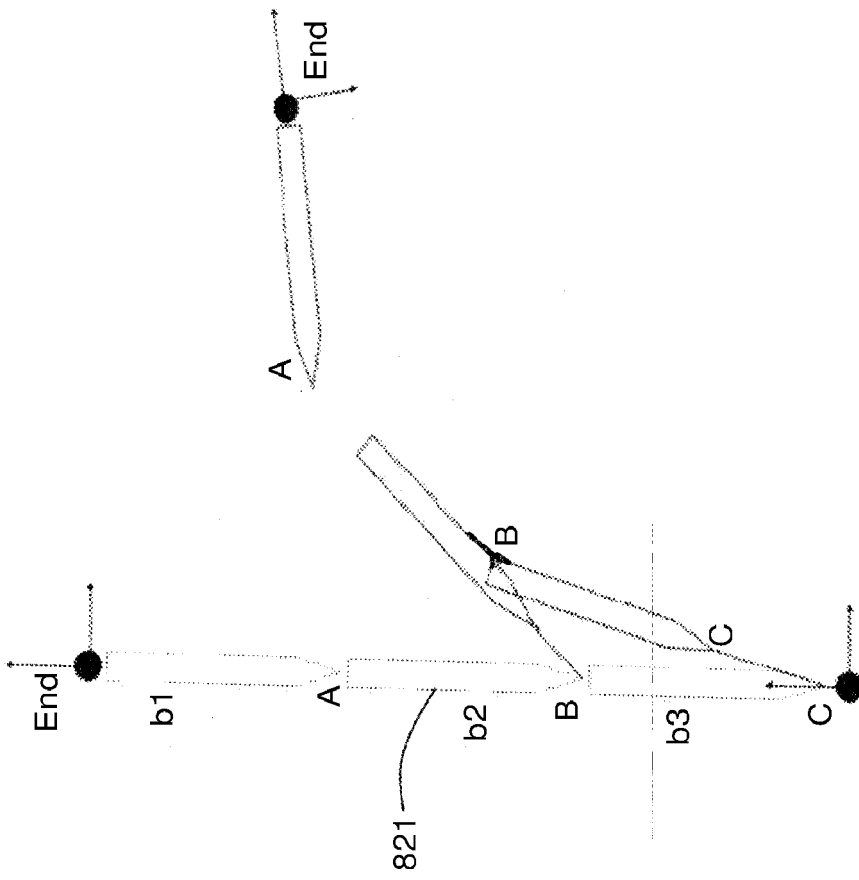

FIG. 8G

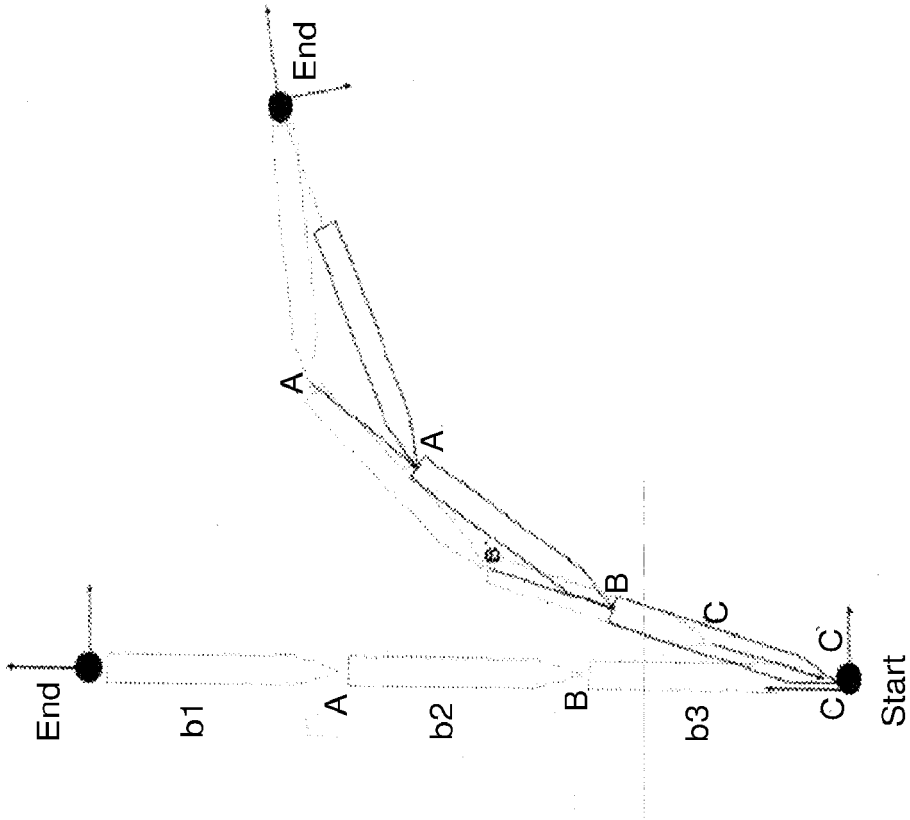

FIG. 8H

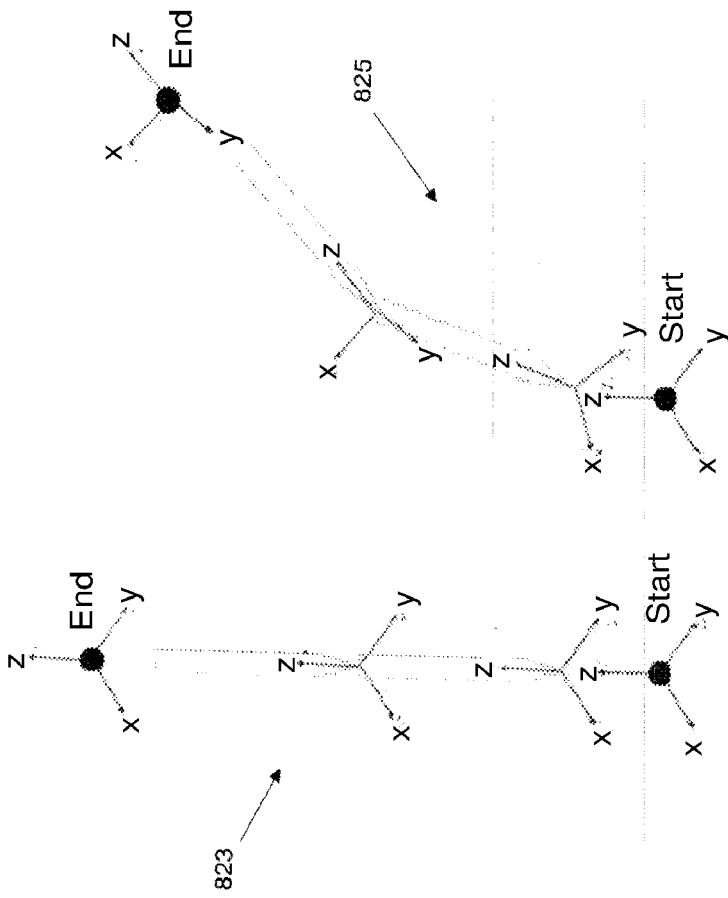

FIG. 8i

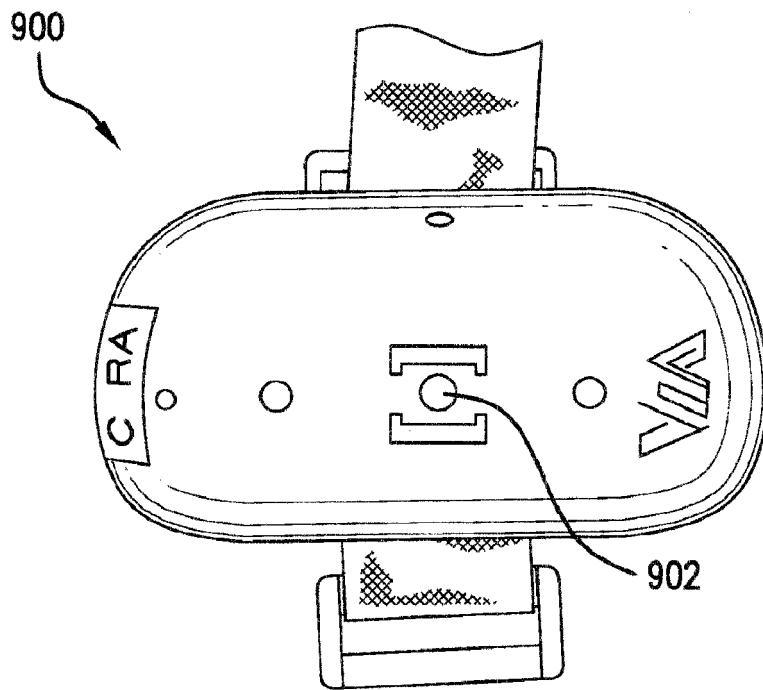

FIG. 9A

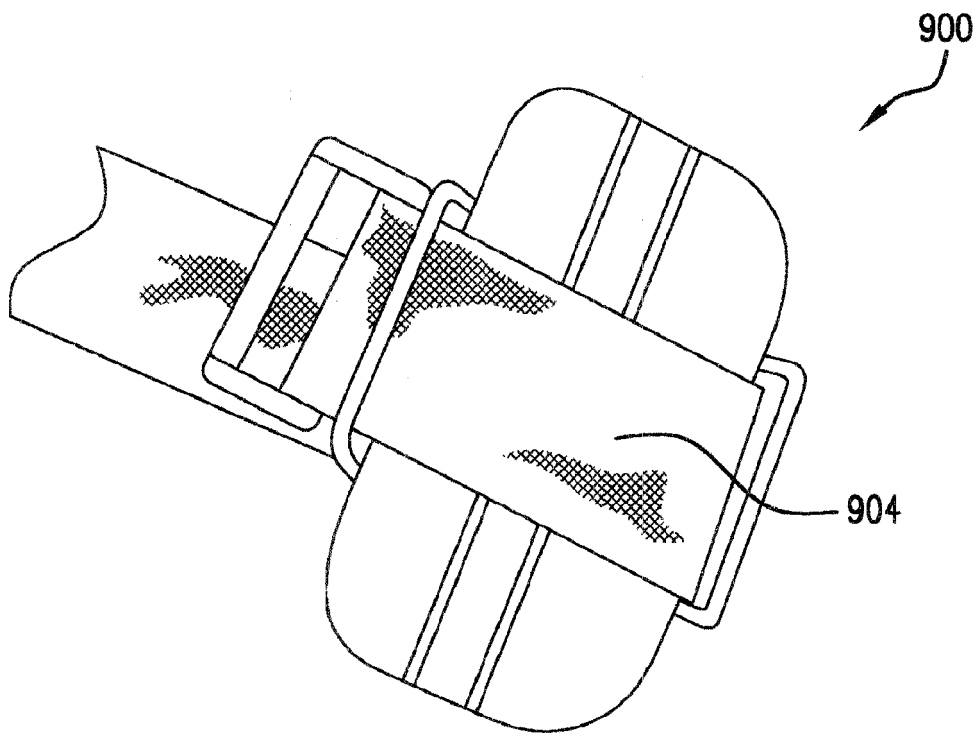

FIG. 9B

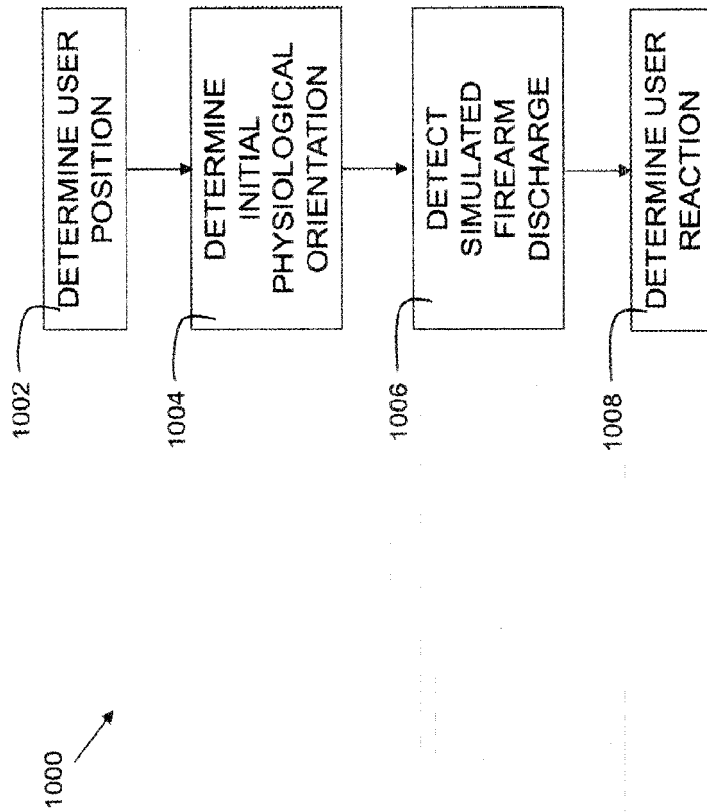

FIG. 10

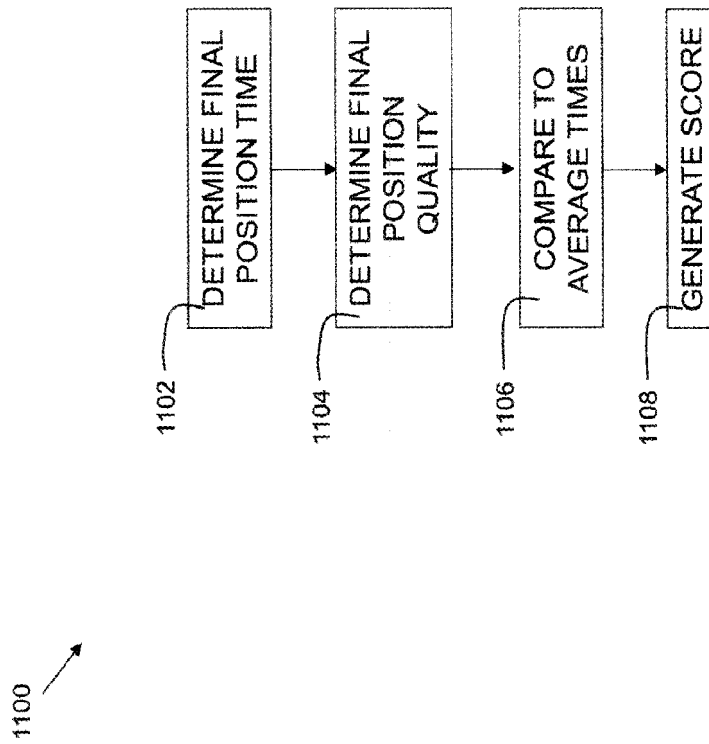
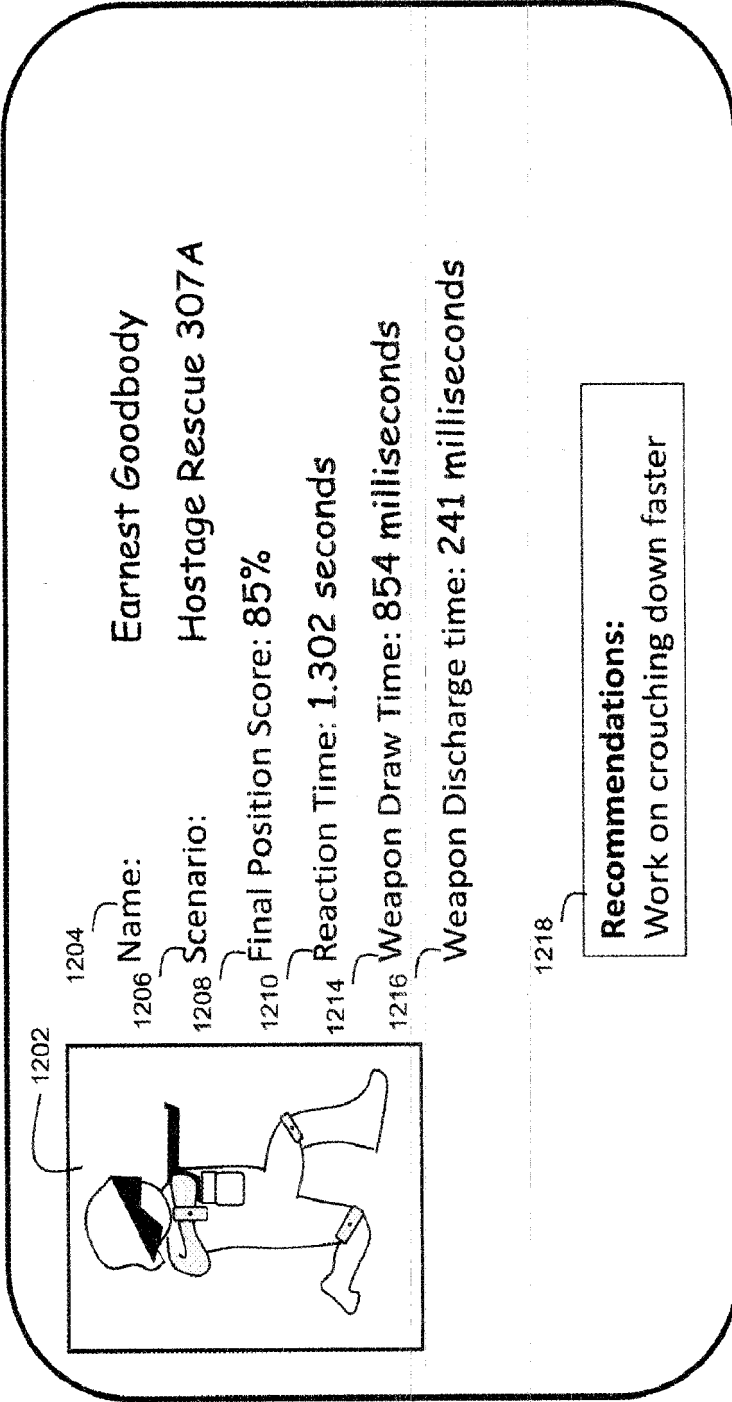
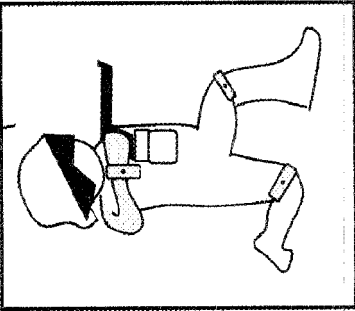

FIG. 11

1200



1202 

1204 **Name:** Earnest Goodbody

1206 **Scenario:** Hostage Rescue 307A

1210 **Final Position Score:** 85%

1214 **Reaction Time:** 1.302 seconds

1216 **Weapon Draw Time:** 854 milliseconds

Weapon Discharge time: 241 milliseconds

1218 **Recommendations:**
Work on crouching down faster

Detailed description: The image shows a user profile card for 'Earnest Goodbody' in a 'Hostage Rescue 307A' scenario. The card includes a profile picture (1202) of a soldier, a name field (1204), a scenario field (1206), and performance metrics for Final Position Score (1210), Reaction Time (1214), Weapon Draw Time (1216), and Weapon Discharge time. A recommendations box (1218) suggests 'Work on crouching down faster'. The entire card is labeled 1200.

FIG. 12

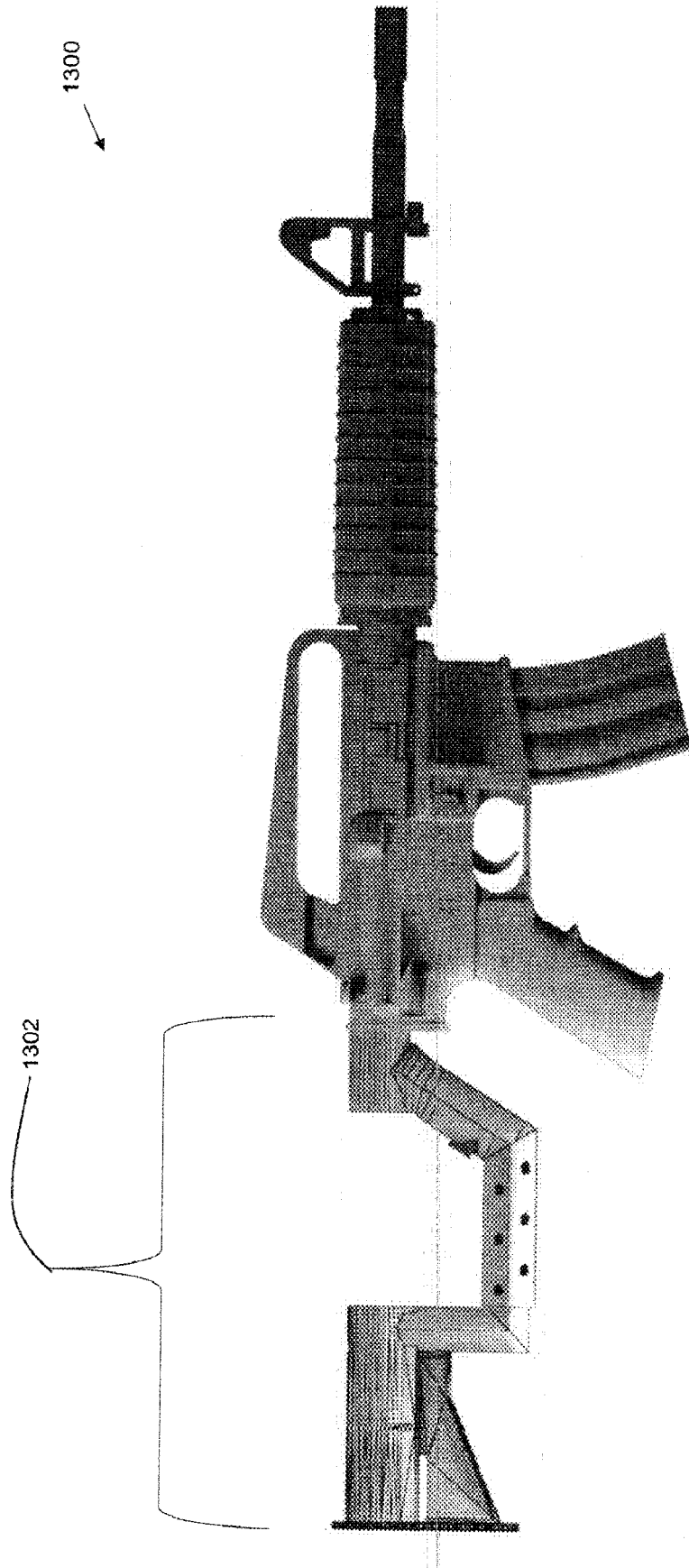

FIG. 13

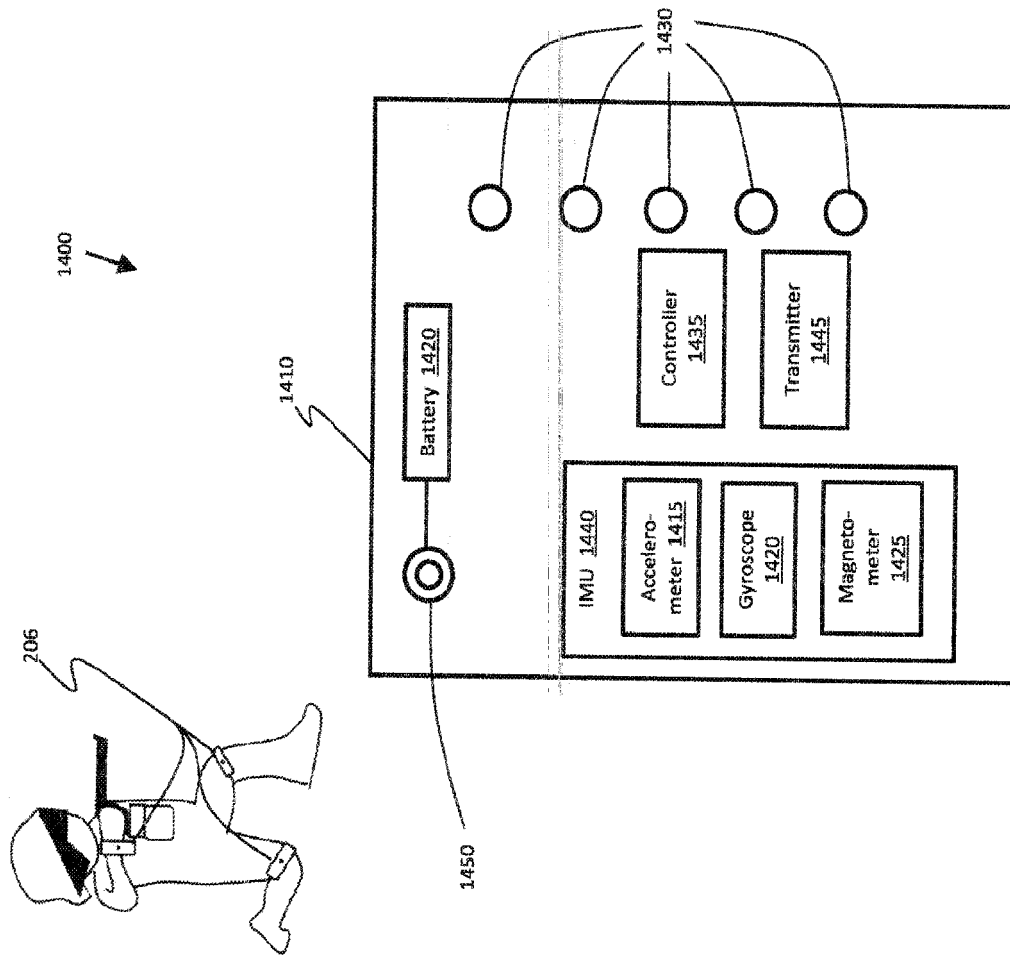

FIG. 14

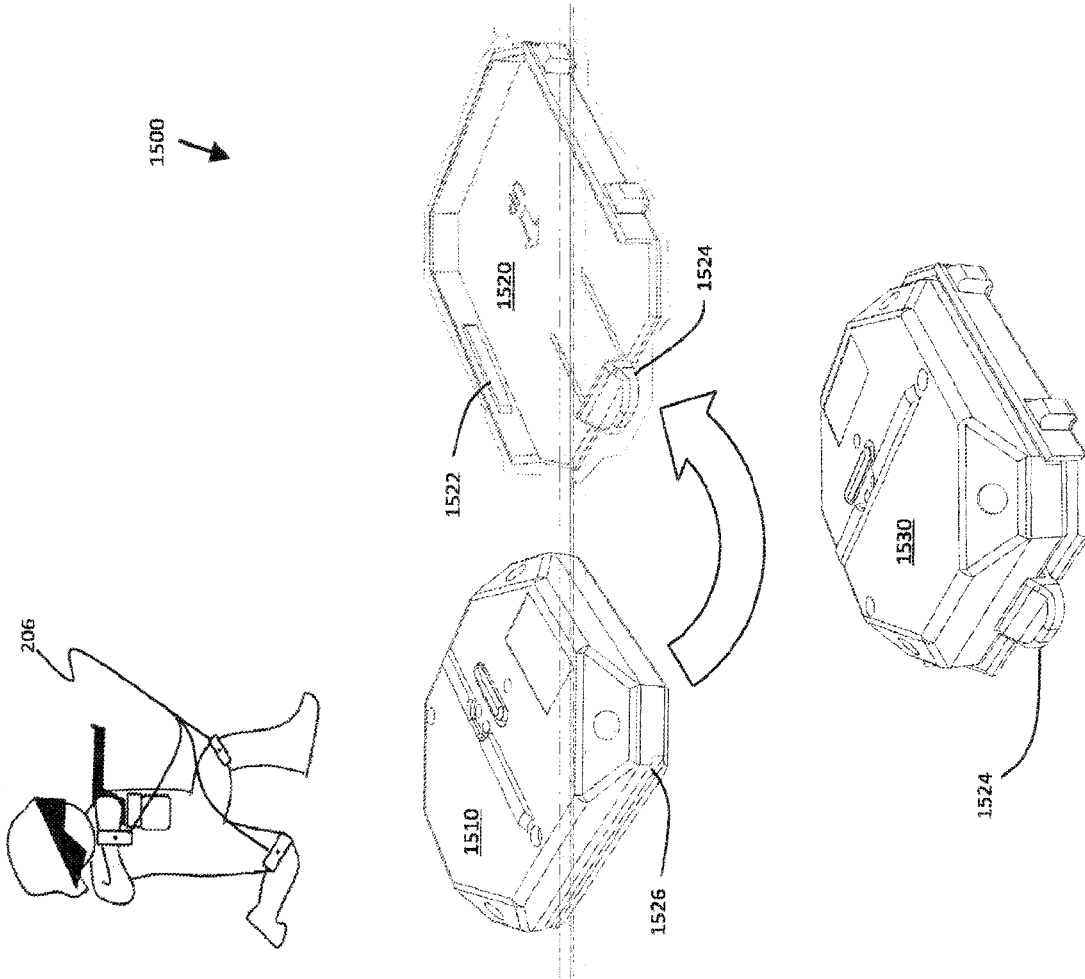

FIG. 15A

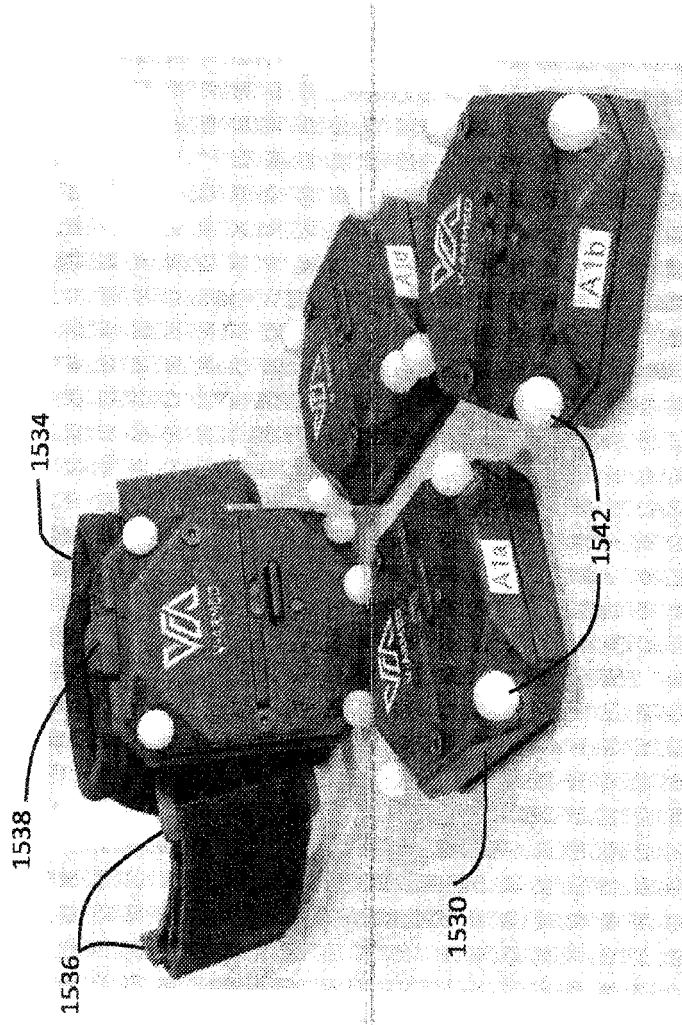

FIG. 15B

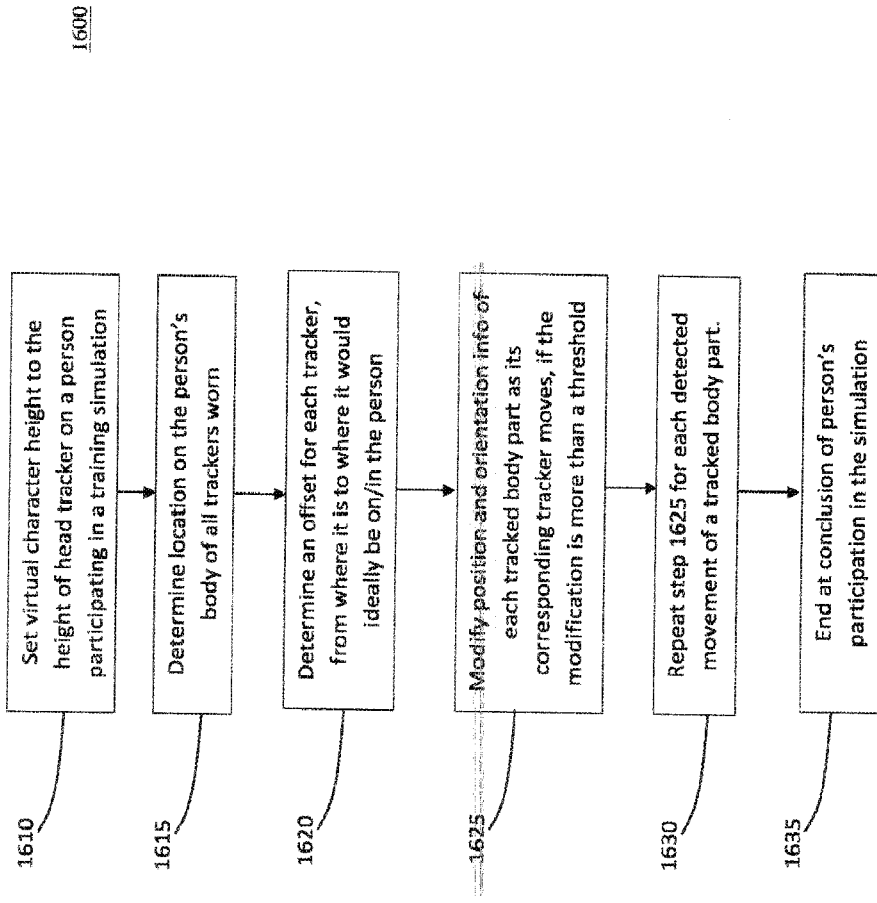

FIG. 16

INTERNATIONAL SEARCH REPORT

International application No.

PCT/US 21/32375

A. CLASSIFICATION OF SUBJECT MATTER

IPC - G09B 9/00; G06F 3/01; F41A 33/02; F41G 3/26 (2021.01)

CPC - G09B 9/003; G06F 3/013; F41A 33/02; F41G 3/2622I F41G 3/2694; G06F 3/012

According to International Patent Classification (IPC) or to both national classification and IPC

B. FIELDS SEARCHED

Minimum documentation searched (classification system followed by classification symbols)

See Search History document

Documentation searched other than minimum documentation to the extent that such documents are included in the fields searched

See Search History document

Electronic data base consulted during the international search (name of data base and, where practicable, search terms used)

See Search History document

C. DOCUMENTS CONSIDERED TO BE RELEVANT

Category*	Citation of document, with indication, where appropriate, of the relevant passages	Relevant to claim No.
Y --- A	US 2007/0273610 A1 (Baillot) 29 November 2007 (29.11.2007) entire document, especially: fig 1, para [0011], [0019], [0021]	1, 2, 6-12, 16 ----- 3-5, 13-15, 17
Y --- A	US 2019/0213901 A1 (V-Armed Inc.) 11 July 2019 (11.07.2019) entire document, especially: fig 1, 9a, 9b, para [0047]-[0049], [0074]	1, 2, 6-12, 16 ----- 3-5, 13-15, 17-20
A	US 2006/0287025 A1 (French) 21 December 2006 (21.12.2006) entire document, especially: para [0003], [0038]	18-20
A	US 10,242,501 B1 (WorldViz, Inc.) 26 March 2019 (26.03.201) entire document	1-20

Further documents are listed in the continuation of Box C.

See patent family annex.

* Special categories of cited documents:

"A" document defining the general state of the art which is not considered to be of particular relevance

"D" document cited by the applicant in the international application

"E" earlier application or patent but published on or after the international filing date

"L" document which may throw doubts on priority claim(s) or which is cited to establish the publication date of another citation or other special reason (as specified)

"O" document referring to an oral disclosure, use, exhibition or other means

"P" document published prior to the international filing date but later than the priority date claimed

"T" later document published after the international filing date or priority date and not in conflict with the application but cited to understand the principle or theory underlying the invention

"X" document of particular relevance; the claimed invention cannot be considered novel or cannot be considered to involve an inventive step when the document is taken alone

"Y" document of particular relevance; the claimed invention cannot be considered to involve an inventive step when the document is combined with one or more other such documents, such combination being obvious to a person skilled in the art

"&" document member of the same patent family

Date of the actual completion of the international search

15 July 2021

Date of mailing of the international search report

AUG 23 2021

Name and mailing address of the ISA/US

Mail Stop PCT, Attn: ISA/US, Commissioner for Patents
P.O. Box 1450, Alexandria, Virginia 22313-1450

Facsimile No. 571-273-8300

Authorized officer

Kari Rodriguez

Telephone No. PCT Helpdesk: 571-272-4300